

# TPL251

## LOW LEVEL ORDER PICKER 2.5T

2500 kg
 120 mm
 24 V Li-ion



The TPL251 is the ideal solution for high-volume order picking and long-distance horizontal transport in distribution centers, retail logistics, and manufacturing supply chains. Designed for low-level order picking, it allows operators to efficiently collect goods along aisles while maintaining excellent control and visibility. With walk-along side buttons for precise truck movement and an ergonomic suspended platform, the TPL251 enhances both productivity and operator well-being in demanding warehouse operations.

SPECIFICATION	REF	UNIT	VALUE
Battery type			Li-ion
Battery nominal capacity K5		Ah	280
Battery voltage		V	24
Rated capacity	Q	kg	2500
Load centre distance	c	mm	600
Service weight		kg	821
Lift	$h_3$	mm	120
Overall length	$l_1$	mm	2526
Overall width	$b_1/b_2$	mm	804
Length to face of forks	$l_2$	mm	1375
Fork dimensions	s/e/l	mm	55/190/1150
Turning radius	Wa	mm	2172
Manufacturer			EP
Model designation			TPL251
Drive			Electric
Operator type			Stand-on

# Features

## High-speed performance and dual-pallet handling

With a top travel speed of 14.5 km/h, the TPL251 significantly increases throughput for long-distance order picking. The optional 2400 mm forks enable the handling of two pallets simultaneously, optimizing load cycles and minimizing travel time between aisles.



## Advanced Li-ion power system

Powered by a 24V/280Ah Li-ion battery, the TPL251 ensures long-lasting performance with zero maintenance and opportunity charging via an external plug. Optional 410Ah capacity provides even longer runtime, making it ideal for multi-shift operations without downtime.

## Ergonomic and comfortable operator station

Designed for operator well-being, the suspended platform and low-step entrance minimize vibration and fatigue. The foam backrest and wide standing space provide comfort during long shifts, while optional storage brackets accommodate accessories like scanners or WMS terminals.



## Precision handling and easy operation

Equipped with electric power steering and automatic center positioning, the TPL251 ensures effortless control. Walk-along side buttons allow operators to move the truck alongside them during picking, improving workflow and reducing unnecessary steps between stops.

# VDI Chart

	SPECIFICATION	REF	UNIT	VALUE
1.1	Manufacturer			EP
1.2	Model designation			TPL251
1.3	Drive			Electric
1.4	Operator type			Stand-on
1.5	Rated capacity	Q	kg	2500
1.6	Load centre distance	c	mm	600
1.8	Load distance, centre of drive axle to fork	x	mm	980
1.9	Wheelbase	y	mm	2117
2.1	Service weight		kg	821
2.2	Axle loading, laden front/rear		kg	1050/2271
2.3	Axle loading, unladen front/rear		kg	600/221
3.1	Tyres			Polyurethane
3.2	Tyre size, front		mm	Φ260x105
3.3	Tyre size, rear		mm	Φ85x70
3.4	Additional wheels (castor wheels)		mm	Φ180x65
3.5	Wheels, number front/rear (x=drive wheels)			1x+1/4
3.6	Tread width, front	b <sub>10</sub>	mm	465
3.7	Tread width, rear	b <sub>11</sub>	mm	370/515
4.2.1	Overall height		mm	1273
4.4	Lift	h <sub>3</sub>	mm	120
4.9	Height drawbar in driving position min./max.	h <sub>14</sub>	mm	1273
4.15	Height, lowered	h <sub>13</sub>	mm	85
4.16	Length of loading surface			1375
4.19	Overall length	l <sub>1</sub>	mm	2526
4.20	Length to face of forks	l <sub>2</sub>	mm	1375
4.21	Overall width	b <sub>1</sub> /b <sub>2</sub>	mm	804
4.22	Fork dimensions	s/e/l	mm	55/190/1150
4.25	Distance between fork-arms	b <sub>5</sub>	mm	560/685
4.32	Ground clearance, centre of wheelbase	m <sub>2</sub>	mm	30
4.34.1	Aisle width for pallets 1000×1200 crossways	Ast	mm	3006
4.34.2	Aisle width for pallets 800 × 1200 lengthways	Ast	mm	2941
4.35	Turning radius	wa	mm	2172

	SPECIFICATION	REF	UNIT	VALUE
5.1	Travel speed, laden/unladen		km/h	9.5/14.5
5.2	Lift speed, laden/unladen		m/s	0.032/0.044
5.3	Lowering speed, laden/unladen		m/s	0.045/0.037
5.8	Max. gradeability, laden/unladen		%	5/16
5.10	Service brake			Electromagnetic
5.11	Parking brake			Electromagnetic
6.1	Drive motor rating S2 60 min		kW	3.3
6.2	Lift motor rating at S3 15%		kW	2.2
6.4	Battery nominal capacity K5		Ah	280
6.4	Battery voltage		V	24
6.4.1	Battery type			Li-ion
6.5	Battery weight		kg	76
6.6	Energy consumption according to DIN EN 16796		kWh/h	0.494 <sup>1)</sup>
6.7	Turnover output according to VDI 2198			117.5
6.8	Turnover efficiency according to VDI 2198			112.12
8.1	Type of drive unit			AC
10.5	Steering design			Electronic
10.7	Sound pressure level at the driver's seat		dB(A)	74

# VDI Drawing

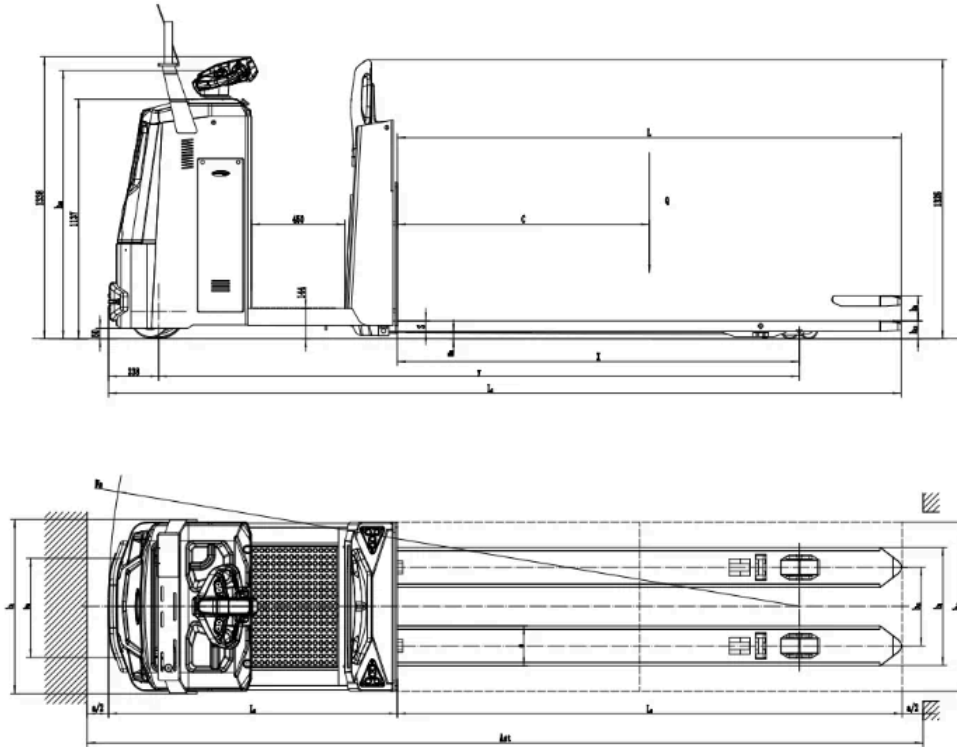

## Options

ITEM	OPTIONS (optional items marked in yellow)
Fork lowered height	85
Load wheel type	Double
Load wheel material	PU
Drive wheel material	PU
Battery capacity	280Ah (Li-ion)   410Ah (Li-ion)
Charger	24V-100A external charger   24V-50A external charger
Battery display indicator (BDI)	With hourmeter (Bluetooth)
Front lamp	Front lamp
USB interface	USB interface
Fork length	1150   850/1000/1220/1300/1450/1600/1800 /2000/2200/2400
Fork width	560/685