

# BENDI B420 RWD

## BATTERY ELECTRIC MULTI-PURPOSE ARTICULATED FORKLIFT TRUCK

Designed to give optimal aisle performance whilst retaining many of the features which have made the award winning Bendi the first choice in articulated forklift trucks, the B420 is capable of storing pallets in aisles as small as 1.65m offering great space savings over counterbalance and reach trucks. Bendi can achieve a storage density that exceeds that of a very narrow aisle (VNA) installation.

### Standard Features:

- Battery electric
- 2000kg capacity
- 10m lift
- 1.65m aisle
- Dual inside / outside

### Ergonomics & Safety

- Comfortable seating position with all truck functions to hand
- No 'deadman switch' required as rotation fully visible from drivers cab
- Four post overhead guard
- Full hydraulic power steering

### Drivetrain

- Large soft tyres
- Regenerative braking
- Powerful 12kW AC drive motor
- 220° over rotating steering

### Electrical System

- 48 volt high capacity battery
- Maintenance free AC control
- Battery and status monitoring display
- Provision for radio data terminals / RFID reader

### Engineering

- Full backwards and forwards tilting mast
- Accepts all standard attachments
- Lifetime warranty on articulation unit
- Award winning chassis design
- Patented rear wheel drive



# TRANSLIFT

WWW.TRANSLIFT.CO.UK  
SALES@TRANSLIFT.CO.UK  
CALL US: 01527 527 411

## TECHNICAL DATA BENDI B420 RWD

Model		B420		
Capacity		kg	2000	
Load centre		mm	500	
Power source			Traction Battery	
Unladen weight including battery		kg	7400	
Sideshift			Integral	
Travel speed (adjustable)		Laden / Unladen	kph	13/14
Lift Speed		Laden / Unladen	m/s	0.4/0.5
Lower speed		Laden / Unladen	m/s	0.5/0.3
Tilt range		Fore/Rear	°	1/3
Overhead guard height	g	mm	2250	
Seat height	f	mm	1220	
Cab floor height	e	mm	700	
Minimum ground clearance	d	mm	80	
Lost load centre	a	mm	270	
Overall length to face of forks	c	mm	2700	
Wheelbase	b	mm	1840	
Chassis width	h	mm	1280	
Maximum gradient		%	15	
Rotation angle		°	220	
Combined Lift and power steer motor rating		kW	8	
Drive motor rating - AC		kW	6x2	
Wheel size		Front / Rear	mm	305 x 150 / 460 x 200
Battery type, standard		720	Ah	8PZSH720
Minimum battery weight			kg	1050
Control type				AC



## MAST DIMENSIONS

Standard triple full free lift mast

Lift Height	Free Lift	Closed Height	Extended Height	Lift Height
5000 mm	1912 mm	2437 mm	5537 mm	5000 mm
6000 mm	2279 mm	2804 mm	6537 mm	6000 mm
7150 mm	2662 mm	3175 mm	7687 mm	7150 mm
8200 mm	3245 mm	3770 mm	8737 mm	8200 mm
9000 mm	3512 mm	4037 mm	9537 mm	9000 mm
10000 mm	3879 mm	4404 mm	10537 mm	10000 mm

All heights are stated without load backrest, if fitted

## AISLE DIMENSIONS

Load Depth x Width (j x i)	Minimum Clear Aisle
1000mm D x 1200mm W	1650 mm
1200mm D x 1000mm W	1850 mm
1200mm D x 800mm W	1850 mm
Minimum clear transfer aisle	2700 mm
Minimum end aisle clearance	750 mm

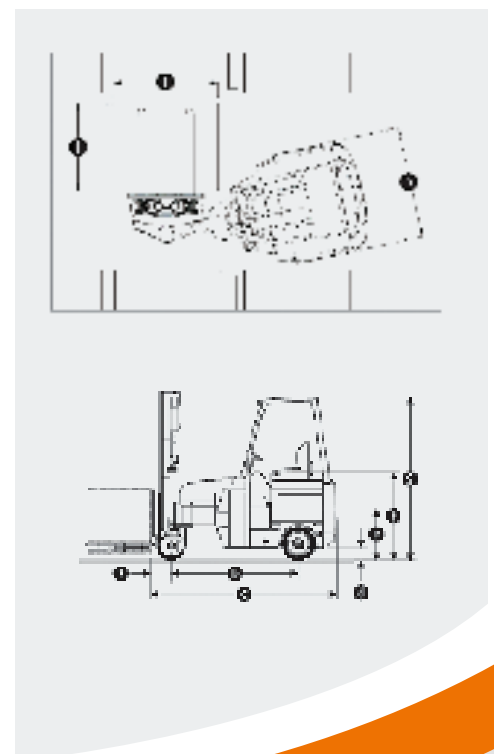

# TRANSLIFT

WWW.TRANSLIFT.CO.UK  
SALES@TRANSLIFT.CO.UK  
CALL US: 01527 527 411

**BENDI B420 RWD TECHNICAL DATA**