

TDL162

COUNTERBALANCE FORKLIFT TRUCK 1.6 T

 1600 kg  6000 mm  80 V Li-Ion



Indoor/Outdoor Versatility: Designed for high-end use in large warehouses, docks, side-bay lorries, and logistics centres.

Productive Operations: Equipped with dual-drive power and ergonomic features to support long shifts in high-demand settings.

Adaptable to Conditions: Optional configurations like joystick control and heated cabin provide flexibility for varying operational environments.

SPECIFICATION	REF	UNIT	VALUE
Battery type			Li-Ion
Battery nominal capacity		Ah	280
Battery voltage		V	80
Load capacity	Q	kg	1600
Load centre distance	c	mm	500
Service weight		kg	3146
Retracted mast height	h_1	mm	1985
Lift height	h_3	mm	3000
Height, mast extended	h_4	mm	3650
Overall length		mm	2935
Overall width	b_1/b_2	mm	1050
Length to face of forks	l ₂	mm	2015
Fork dimensions	s/e/l	mm	40X100X920
Turning radius		Wa	1639
Operator type			Seated
Load distance, centre of drive axle to fork		mm	375

Features

Outstanding performance for productivity boost

Thanks to the optimised structure and design, the TDL162 features significant increases in travel speed, lifting speed, lowering speed, residual load capacity and max gradeability, compared to its class. The forklift maintains the nominal capacity of 1600kg up to 4.35 metres elevation with triple-stage mast, demonstrating exceptional stability and performance. With these outstanding strengths, the TDL162 speeds up warehouse turnover and maximises transport efficiency.

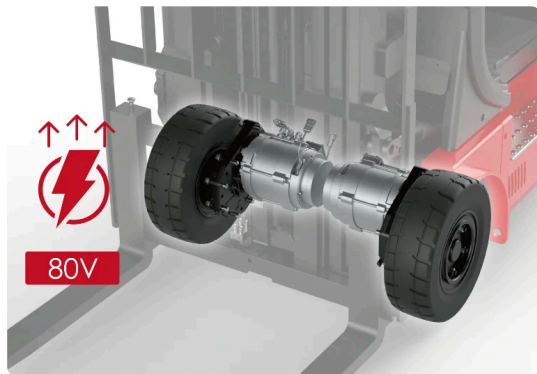

80V Li-ion dual-drive power system for high energy efficiency

The dual-drive power system of the TDL162 has been upgraded from 48V to 80V and the truck comes with an 80V/280Ah Li-ion battery as standard, ensuring lower energy consumption, a powerful drive and long endurance.

2 charging possibilities on the same truck

TDL162 comes standard with a single-phase integrated charger with plug and a plug for an external charger. Thanks to this new feature, TDL162 charging becomes extremely flexible and can meet all kinds of application needs up to multi-shift operation using an external fast charger.



Ergonomic design to improve driving comfort and convenience

The TDL162 is designed around ergonomic requirements: a large workspace, improved steering sensitivity, wider visibility, a lower noise level and an informative LED display with performance selector switch, all of which provide the driver with a comfortable and safe operation experience.



Premium options to fulfil high-end needs

The TDL162 can be fitted with the joystick option positioned at the end of the armrest to replace manual levers and it allows all controls to be performed in a palm-sized area without fatigue: all hydraulic functions, direction changes, horn, and emergency stop, all within a compact, ergonomic design. For operations in challenging weather, the all-weather cabin option extends the forklift's operation across various conditions, ensuring consistent productivity regardless of the environment.



VDI Chart

	SPECIFICATION	REF	UNIT	VALUE
1.4	Operator type			Seated
1.5	Load capacity	Q	kg	1600
1.6	Load centre distance	c	mm	500
1.8	Load distance, centre of drive axle to fork		mm	375
1.9	Wheelbase		mm	1470
2.1	Service weight		kg	3146
2.2	Axle loading, laden front/rear		kg	4129/617
2.3	Axle loading, unladen front/rear		kg	1576/1570
3.1	Tyre type			Solid rubber
3.2	Tyre size, front		mm	18x7-8
3.3	Tyre size, rear		mm	140/55-9
3.5	Wheels, number front/rear (x=drive wheels)			2X/2
3.6.1	Tread width, front	b ₁₀	mm	910
3.7.1	Tread width, rear	b ₁₁	mm	210
4.0	Max lift height	H	mm	6000
4.1	Tilt of mast/fork carriage forward/backward		°	7/6
4.12	Tow coupling height		mm	580
4.19	Overall length		mm	2935
4.2	Retracted mast height	h ₁	mm	1985
4.20	Length to face of forks	l ₂	mm	2015
4.21	Overall width	b ₁ /b ₂	mm	1050
4.22	Fork dimensions	s/e/l	mm	40X100X920
4.23	A,B Fork carriage class/type A, B			2A

	SPECIFICATION	REF	UNIT	VALUE
4.24	Fork carriage width		mm	1040
4.3	Free lift		mm	500
4.31	Ground clearance, laden, below mast		mm	90
4.32	Ground clearance, centre of wheelbase		mm	107
4.34.1	Aisle width for pallets 1000×1200 crossways		Ast	3339
4.34.2	Aisle width for pallets 800×1200 lengthways		Ast	3464
4.35	Turning radius		Wa	1639
4.4	Lift height	h ₃	mm	3000
4.5	Height, mast extended	h ₄	mm	3650
4.7	Height of overhead guard (cabin)		mm	2140
4.8	Seat height/standing height		mm	1070
5.1	Travel speed, laden/unladen		km/h	16/17
5.10	Service brake			Electromagnetic
5.11	Parking brake			Electromagnetic
5.2	Lifting speed, laden/unladen		m/s	0.5/0.52
5.3	Lowering speed, laden/unladen		m/s	0.55/0.55
5.8	Max. gradeability, laden/unladen		%	20/25
6.1	Drive motor rating S2 60 min		kW	5.4X2
6.2	Lift motor rating at S3 15%		kW	18
6.4	Battery nominal capacity		Ah	280
6.4	Battery voltage		V	80
6.4.1	Battery type			Li-Ion
6.5	Battery weight		kg	220
8.1	Type of drive control			AC
10.5	Steering design			Hydraulic
10.7	Sound pressure level at the drivers ear		dB(A)	65
15.1	Charger output current		A	35

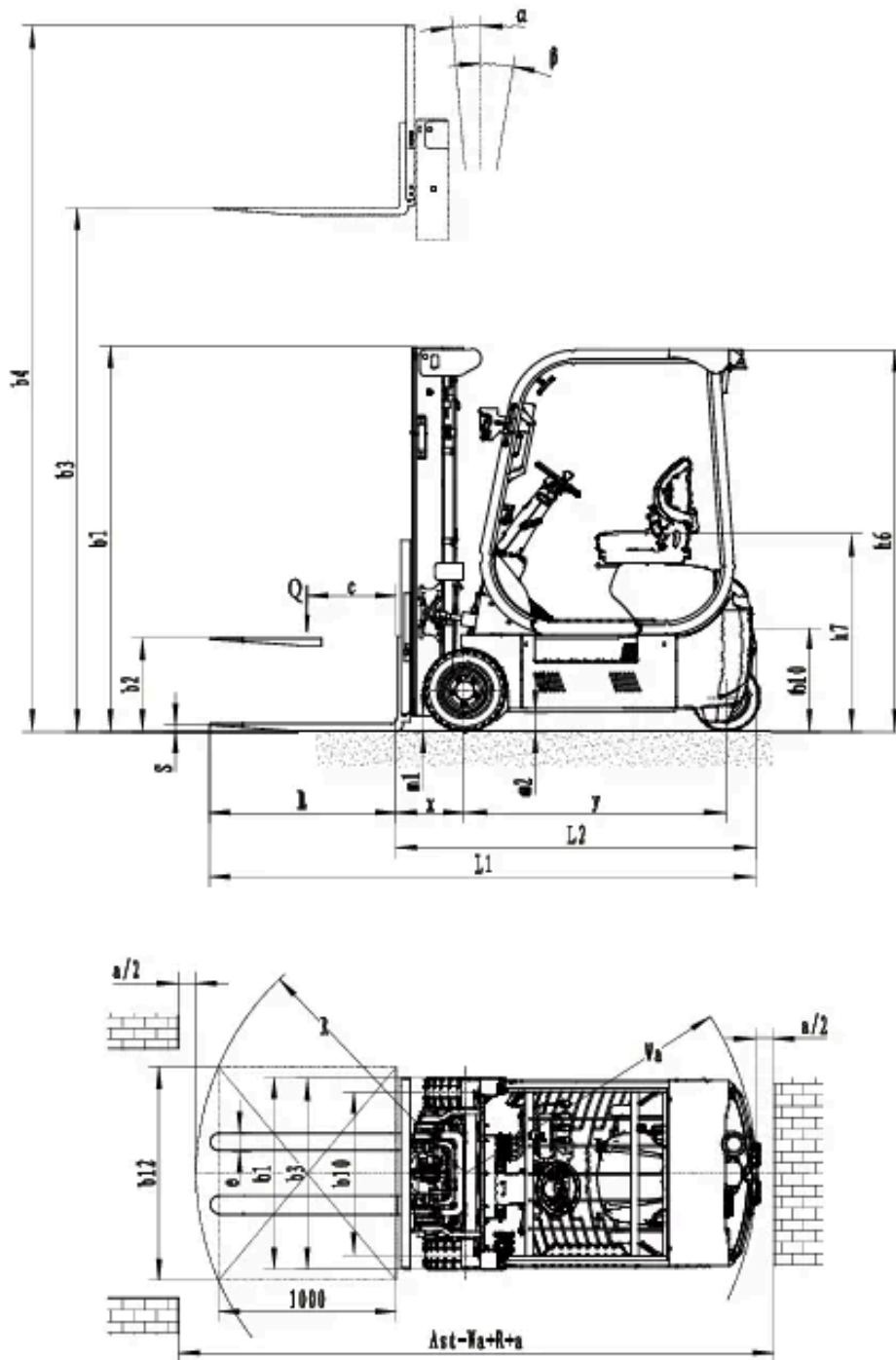

RATED CAPACITIES AND LOAD CENTERES GRAPH

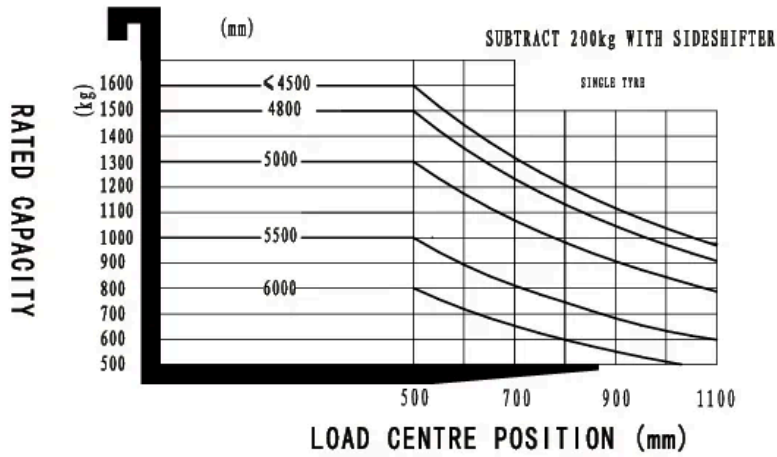

Mast Options

MAST TYPE	LIFT HEIGHT (H3, MM)	MAST LOWERED HEIGHT (H1, MM)	MAST EXTENDED HEIGHT, NO BACKREST (H4, MM)	MAST EXTENDED HEIGHT, WITH BACKREST (H4, MM)	FREE LIFT HEIGHT, NO BACKREST (H2, MM)	FREE LIFT HEIGHT, WITH BACKREST (H2, MM)	HEIGHT, MAST EXTENDED, NO SHELVING (H4, MM)	HEIGHT, MAST EXTENDED, WITH SHELVING (H4, MM)	HEIGHT, FREE LIFT, NO SHELVING (H2, MM)
2-Standard Mast	3000	1985	3650	3965	100	100	7	6	375
2-Standard Mast	3600	2285	4250	4565	100	100	7	6	375
2-Standard Mast	4000	2365	4650	4965	100	100	7	6	375
3-Free Mast	4000	1860	4650	4965	1140	825	7	6	387
3-Free Mast	4350	2010	5000	5315	1290	975	7	6	387
3-Free Mast	4500	2050	5150	5465	1340	1025	7	6	387
3-Free Mast	4800	2150	5450	5765	1440	1125	7	6	387
3-Free Mast	5000	2215	5650	5965	1505	1190	7	6	387
3-Free Mast	5500	2385	6150	6465	1675	1360	7	6	387
3-Free Mast	6000	2600	6650	6965	1890	1575	7	6	387

Options

ITEM	OPTIONS (optional items marked in yellow)
Fork dimension	100*40*920 100*40*1070 100*40*1100 100*40*1150 100*40*1220 100*40*1370 100*40*1520 100*40*1800
Seat type	Comfortable Suspension Suspension with armrests
Attachments	No Built-in sideshifter External shifter Fork positioner with sideshift
Traction pin	Yes and not customized
Front wheel material	Normal solid Traceless solid
Rear wheel material	Normal solid Traceless solid
Battery capacity	80V280Ah
Charger	80V35A internal 80V60A external 80V100A external 80V150A external
Battery display indicator (BDI)	With hourmeter (Bluetooth) without PSE
Area warning lamp	No Both side Both side and rear
Rearview mirror	One in front Two on side and one in front
Buzzer	Yes and not customized
OPS system	Yes and not customized
USB interface	No Yes and not customized
Telematics	Yes and not customized
Front lamp	LED
Rear lamp	No LED
Warning lamp	Yes and not customized
Blue lamp	No Front Rear Front and rear
Cabin	No Basic half cabin Upgrade half cabin Full cabin
Overhead guard	Yes and not customized
Anti-static chain	Yes and not customized
Turn signal light	LED
Special AUS/NZ options	No Yes and not customized(only for Australia standard)
Turn speed control	Yes and not customized
Heating system during lithium battery charging	No Yes and not customized
Operator identification device	No Swipe card device Fingerprint lock
Lifting electronic limit	Yes and not customized
Hydraulic control	Mechanical lever Joystick Fingertip

ITEM**OPTIONS (optional items marked in yellow)**

Rear armrest horn

Yes and not customized
