



# RSi201

## HEAVY-DUTY DOUBLE-DECK STACKER 2.0T

2000 kg 1600 mm 24 V



The RSi201 is engineered for intensive goods handling and order-picking tasks in warehouses, distribution centers, and logistics hubs. With its ability to handle two pallets simultaneously, it maximizes throughput while saving time and labor. The suspended operator platform, electric power steering, and automatic speed reduction on turns ensure comfort and safety during long shifts. Its adaptability to uneven floors and narrow aisles makes it an excellent choice for operations seeking high efficiency in space-constrained environments.

SPECIFICATION	REF	UNIT	VALUE
Battery nominal capacity		Ah	205
Battery voltage		V	24
Load capacity	Q	kg	2000
Load centre distance	c	mm	600
Service weight		kg	860
Retracted mast height	$h_1$	mm	1316
Lift height	$h_3$	mm	1600
Height, mast extended	$h_4$	mm	2112
Overall length		mm	2058
Overall width	$b_1/b_2$	mm	734
Length to face of forks	l <sub>2</sub>	mm	908
Fork dimensions	s/e/l	mm	55×185×1150
Turning radius		Wa	1820
Operator type			Pedestrian
Load distance, centre of drive axle to fork		mm	926
Wheelbase		mm	1550

# Features

---

## Double-deck stacking efficiency

The RSi201's double-deck function allows operators to carry two pallets in one trip, effectively doubling throughput and reducing the number of travel cycles needed in high-demand operations.



## Powerful and precise lifting

A 3kW lift motor delivers lifting speeds up to 0.18 m/s and lowering speeds up to 0.36 m/s, ensuring fast yet smooth handling. The proportional lift control adds accuracy, protecting loads during stacking.

## Advanced Li-ion battery system

The 24V/205Ah Li-ion battery with integrated 30A charger supports opportunity charging for longer uptime. An optional 100A external charger reduces recharge time to just 2 hours, maximizing productivity.





## Operator comfort and safety

A suspended foldable platform with electric power steering reduces fatigue on long routes, while automatic speed reduction on turns, ergonomic tiller, and transparent mast shield ensure safe and comfortable use.

## VDI Chart

	SPECIFICATION	REF	UNIT	VALUE
1.4	Operator type			Pedestrian
1.5	Load capacity	Q	kg	2000
1.6	Load centre distance	c	mm	600
1.8	Load distance, centre of drive axle to fork		mm	926
1.9	Wheelbase		mm	1550
2.1	Service weight		kg	860
2.2	Axle loading, laden front/rear		kg	960/1900
2.3	Axle loading, unladen front/rear		kg	650/210
3.1	Tyre type			Polyurethane
3.2	Tyre size, front		mm	230×75
3.3	Tyre size, rear		mm	85×70
3.4	Additional wheels (castor wheels)		mm	130×55
3.5	Wheels, number front/rear (x=drive wheels)			1x,2/4
3.6.1	Tread width, front	b <sub>10</sub>	mm	514
3.7.1	Tread width, rear	b <sub>11</sub>	mm	385
4.0	Max lift height	H	mm	1600
4.1	Tilt of mast/fork carriage forward/backward		°	8/16
4.10	Height of wheel arms		mm	Height of wheel arms
4.15	Lowered height			92
4.19	Overall length		mm	2058
4.2	Retracted mast height	h <sub>1</sub>	mm	1316
4.20	Length to face of forks	l <sub>2</sub>	mm	908

SPECIFICATION		REF	UNIT	VALUE
4.21	Overall width	b <sub>1</sub> /b <sub>2</sub>	mm	734
4.22	Fork dimensions	s/e/l	mm	55×185×1150
4.24	Fork carriage width		mm	55×185
4.26	Distance between wheel arms/loading surfaces			570
4.3	Free lift		mm	100
4.31	Ground clearance, laden, below mast		mm	16
4.32	Ground clearance, centre of wheelbase		mm	16
4.34.1	Aisle width for pallets 1000×1200 crossways		Ast	2628
4.34.2	Aisle width for pallets 800×1200 lengthways		Ast	2516
4.35	Turning radius		Wa	1820
4.4	Lift height	h <sub>3</sub>	mm	1600
4.5	Height, mast extended	h <sub>4</sub>	mm	2112
4.6	Initial lift		mm	120
4.9	Height of tiller handle in drive position min./max.			1190/1290
5.1	Travel speed, laden/unladen		km/h	8/8
5.10	Service brake			Electromagnetic
5.11	Parking brake			Electromagnetic
5.2	Lifting speed, laden/unladen		m/s	0.18/0.23
5.3	Lowering speed, laden/unladen		m/s	0.36/0.18
5.8	Max. gradeability, laden/unladen		%	8/16
6.1	Drive motor rating S2 60 min		kW	2.5
6.2	Lift motor rating at S3 15%		kW	3
6.4	Battery nominal capacity		Ah	205
6.4	Battery voltage		V	24
6.5	Battery weight		kg	70
6.6	Energy consumption according to DIN EN 16796		kWh/h	0,262 <sup>1)</sup>
6.7	Turnover output according to VDI 2198			108
6.8	Turnover efficiency according to VDI 2198			138.82
8.1	Type of drive control			AC
10.5	Steering design			Electronic
10.7	Sound pressure level at the drivers ear		dB(A)	74
15.1	Charger output current		A	70

# VDI Drawing

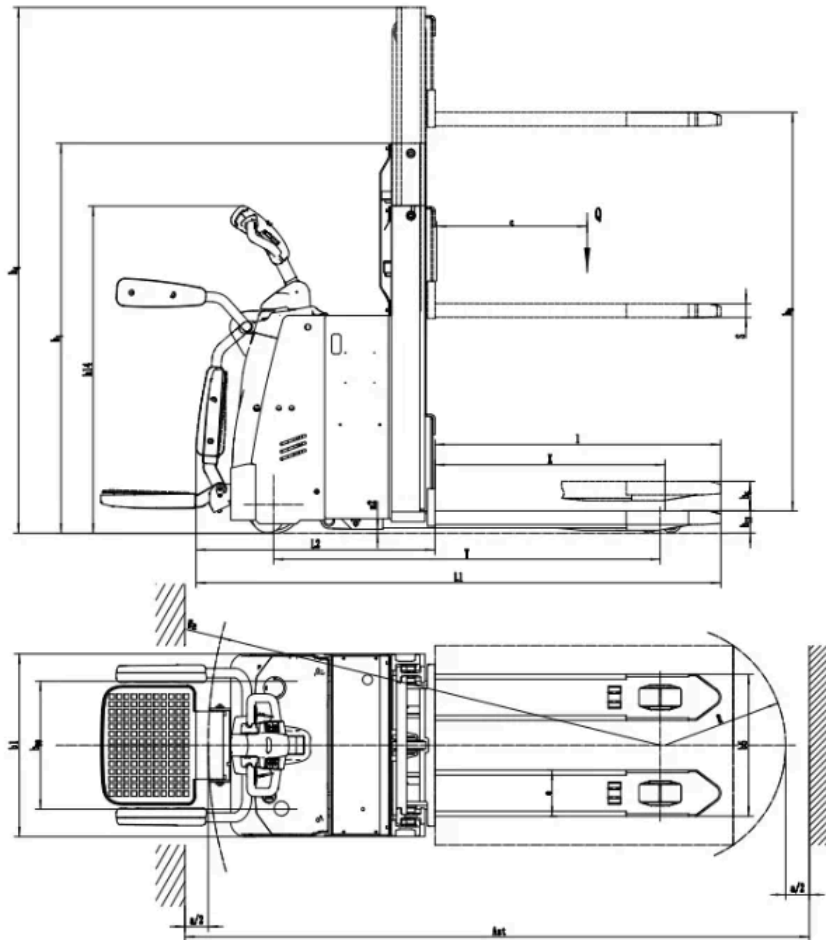

## Options

ITEM	OPTIONS (optional items marked in yellow)
Fork dimension	570*1150   570*1220   685*1220
Load wheel type	Double   Single
Load wheel material	PU
Drive wheel material	PU   Trace PU   Rubber   PU (NDI)
Battery capacity	24V 205Ah Li-ion
Charger	24V/30A Internal   24V/100A external
Battery display indicator (BDI)	With hourmeter (Bluetooth)
Buzzer	No   Yes and not customized
Telematics	No   Yes and not customized
Castor wheels	Yes and not customized
Operator identification device	No   Card reader

**ITEM****OPTIONS (optional items marked in yellow)**

Side supports

205

---