

JX1

MEDIUM LEVEL ORDER PICKER 0.5T 3200

 363 kg  4030|4930|5710 mm  24 V AGM/Lead Acid



The JX1 is ideal for retail distribution centers, e-commerce warehouses, and logistics hubs that require fast and safe picking at medium levels. Thanks to its compact 800 mm chassis, strong and steady design, and maintenance-free AGM battery, it operates reliably in narrow aisles. Optional large lead-acid batteries and simple battery exchange systems provide extended runtime for multi-shift operations.

SPECIFICATION	REF	UNIT	VALUE
Battery type			AGM/Lead Acid
Battery nominal capacity		Ah	224
Battery voltage		V	24
Load capacity	Q	kg	363
Service weight		kg	1242 1340 1646
Retracted mast height	h ₁	mm	1510 2080 2090
Lift height	h ₃	mm	4030 4930 5710
Height, mast extended	h ₄	mm	4540 5970 6750
Overall length		mm	1500 1500 1610
Overall width	b ₁ /b ₂	mm	823 800 876
Turning radius		Wa	1385 1385 1450
Operator type			Standing
Wheelbase		mm	1150 1150 1256
Axle loading, laden front/rear		kg	644/1096 740/1100 837/1309
Axle loading, unladen front/rear		kg	475/767 520/820 670/1036
Tyre type			Polyurethane/Solidrubber

Features

High picking reach

With a maximum platform height of 4.8 m and picking height of 6.3 m, the JX1 ensures efficient access to medium-level racking for fast and precise order fulfillment.

Compact and agile design

At only 800 mm wide with a turning radius of 1385 mm, it is perfectly suited for narrow aisle operations, providing excellent maneuverability in tight spaces.

Efficient and reliable battery system

Equipped with a 24V/224Ah maintenance-free AGM battery, the JX1 also supports optional large lead-acid batteries and simple exchange systems for continuous operations.

Safe and ergonomic operation

Electronic steering, electromagnetic brakes, and excellent mast visibility ensure operator confidence, while ergonomic controls enhance comfort during long shifts.

VDI Chart

	SPECIFICATION	REF	UNIT	VALUE
1.4	Operator type			Standing
1.5	Load capacity	Q	kg	363
1.9	Wheelbase		mm	1150 1150 1256
2.1	Service weight		kg	1242 1340 1646
2.2	Axle loading, laden front/rear		kg	644/1096 740/1100 837/1309
2.3	Axle loading, unladen front/rear		kg	475/767 520/820 670/1036
3.1	Tyre type			Polyurethane/Solidrubber
3.2	Tyre size, front		mm	φ230*75
3.3	Tyre size, rear		mm	φ204*76
3.4	Additional wheels (castor wheels)		mm	φ74*48
3.5	Wheels, number front/rear (x=drive wheels)			1x , 2/2

SPECIFICATION		REF	UNIT	VALUE
3.6.1	Tread width, front	b ₁₀	mm	555 555 615
3.7.1	Tread width, rear	b ₁₁	mm	740 740 784
4.14	Stand height, elevated			3200 4100 4880
4.19	Overall length		mm	1500 1500 1610
4.2	Retracted mast height	h ₁	mm	1510 2080 2090
4.21	Overall width	b ₁ /b ₂	mm	823 800 876
4.3	Free lift		mm	-
4.32	Ground clearance, centre of wheelbase		mm	50
4.34.1	Aisle width for pallets 1000×1200 crossways		Ast	-
4.35	Turning radius		Wa	1385 1385 1450
4.4	Lift height	h ₃	mm	4030 4930 5710
4.5	Height, mast extended	h ₄	mm	4540 5970 6750
4.7	Height of overhead guard (cabin)		mm	1590 2120 2120
4.8	Seat height/standing height		mm	250
5.1	Travel speed, laden/unladen		km/h	5.5/5.5
5.10	Service brake			Electromagnetic
5.2	Lifting speed, laden/unladen		m/s	0.17/0.21
5.3	Lowering speed, laden/unladen		m/s	0.35/0.26 0.35/0.26 0.3/0.26
5.8	Max. gradeability, laden/unladen		%	0
6.1	Drive motor rating S2 60 min		kW	1.6
6.2	Lift motor rating at S3 15%		kW	2.2
6.4	Battery nominal capacity		Ah	224
6.4	Battery voltage		V	24
6.4.1	Battery type			AGM/Lead Acid
6.5	Battery weight		kg	163
8.1	Type of drive control			AC
10.5	Steering design			Electronic
10.7	Sound pressure level at the drivers ear		dB(A)	74
15.1	Charger output current		A	25

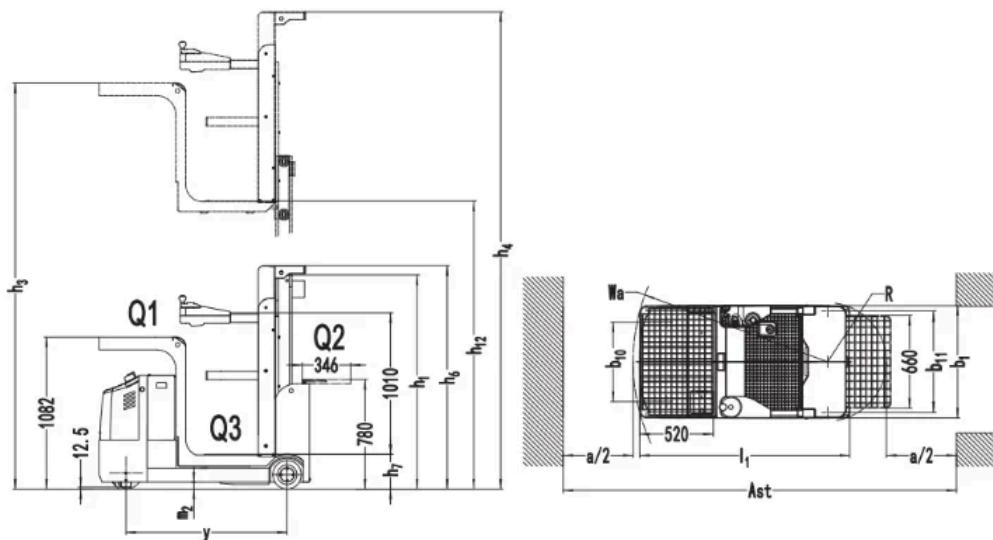

Options

ITEM	OPTIONS (optional items marked in yellow)
Load wheel type	Single
Safe hook	No Yes and not customized
Traction pin	No Yes and not customized
Electrostatic chain	No
Load wheel material	Rubber
Drive wheel material	PU
Battery capacity	No 224AH 210AH 270AH 205AH 280AH (4800mm) 360AH (4800mm)
Charger	No 24V-25A Integrated 24V-40A External 24V-27.1A Integrated
Battery display indicator (BDI)	With hourmeter
Buzzer	Drop buzzer, door alarm buzzer, dip buzzer Running buzzer Reversing buzzer
Guide wheel	No Yes and not customized
USB interface	No Yes and not customized
Castor wheels	Yes and not customized
Water auto-filling system	No
Warning lamp	Front and rear warning light Front blue light + rear warning light Rear blue light + front warning light
Battery side pull function	Yes and not customized

ITEM	OPTIONS (optional items marked in yellow)
Overhead guard	No
Battery side pull attachment	No Yes and not customized