



JX0

COMPACT VERTICAL ORDER PICKER

 200 kg  3615 mm  24 V Lead Acid/Li-ion



The JX0 series is purpose-built for e-commerce, retail, and general warehouse environments where frequent low- to mid-level order picking is required. Its compact 750 mm width and 1260 mm turning radius allow easy operation in narrow aisles and crowded storage areas. The model's automatic travel speed adjustment based on lifting height ensures both efficiency and safety. With options for lead-acid or Li-ion batteries, the JX0 adapts to various working schedules and energy requirements.

SPECIFICATION	REF	UNIT	VALUE
Battery type			Lead Acid/Li-ion
Battery nominal capacity		Ah	120 135
Battery voltage		V	24
Load capacity	Q	kg	200
Load centre distance	c	mm	-
Service weight		kg	800
Retracted mast height	h_1	mm	1375
Lift height	h_3	mm	3615
Height, mast extended	h_4	mm	4090
Overall length		mm	1440
Overall width	b_1/b_2	mm	750
Length to face of forks	l2	mm	-
Fork dimensions	s/e/l	mm	-
Turning radius		Wa	1260
Operator type			Standing
Load distance, centre of drive axle to fork		mm	-

Features

Safe and efficient order picking

The JX0 provides a stable and efficient alternative to ladders and traditional pickers. With a picking height of 4.5 m, it allows operators to reach high racks safely and comfortably, significantly improving picking productivity in tight storage environments.



Intuitive driving and control system

Featuring a mini steering wheel on the left and speed/direction control on the right, the JX0 ensures smooth and precise handling. The integrated LCD display provides clear information about battery level, driving direction, and operating hours, enhancing user awareness and control.

Compact and ergonomic design

With a width of 750 mm and turning radius of only 1260 mm, the JX0 is perfect for narrow aisles. Its spacious operator compartment, fingertip control buttons, and 180° steering capability allow easy, fatigue-free operation throughout extended shifts.



Li-ion battery for maximum uptime

Equipped with a 24V/135Ah Li-ion battery and a single-phase 24V-30A integrated charger, the JX0 supports fast opportunity charging with minimal downtime. The maintenance-free Li-ion system ensures consistent performance, reduced operating costs, and environmental sustainability.

VDI Chart

	SPECIFICATION	REF	UNIT	VALUE
1.4	Operator type			Standing
1.5	Load capacity	Q	kg	200
1.6	Load centre distance	c	mm	-
1.8	Load distance, centre of drive axle to fork		mm	-
1.9	Wheelbase		mm	1095
2.1	Service weight		kg	800
2.2	Axle loading, laden front/rear		kg	673/467
2.3	Axle loading, unladen front/rear		kg	380/420
3.1	Tyre type			Polyurethane/Solidrubber
3.2	Tyre size, front		mm	φ210×70
3.3	Tyre size, rear		mm	φ250×100
3.4	Additional wheels (castor wheels)		mm	φ74×48
3.5	Wheels, number front/rear (x=drive wheels)			1×, 2/2
3.6.1	Tread width, front	b ₁₀	mm	545
3.7.1	Tread width, rear	b ₁₁	mm	640
4.10	Height of wheel arms		mm	-
4.13	Loading height, unladen			-
4.14	Stand height, elevated			3000
4.15	Lowered height			-
4.16	Length of loading surface			-
4.17	Overhang			-
4.19	Overall length		mm	1440
4.2	Retracted mast height	h ₁	mm	1375
4.20	Length to face of forks	l ₂	mm	-
4.21	Overall width	b ₁ /b ₂	mm	750
4.22	Fork dimensions	s/e/l	mm	-
4.3	Free lift		mm	485
4.31	Ground clearance, laden, below mast		mm	-
4.32	Ground clearance, centre of wheelbase		mm	35
4.34.1	Aisle width for pallets 1000×1200 crossways		Ast	-
4.34.2	Aisle width for pallets 800×1200 lengthways		Ast	-
4.35	Turning radius		Wa	1260

SPECIFICATION		REF	UNIT	VALUE
4.36	Internal turning radius			-
4.4	Lift height	h ₃	mm	3615
4.5	Height, mast extended	h ₄	mm	4090
4.6	Initial lift		mm	-
4.7	Height of overhead guard (cabin)		mm	1425
4.8	Seat height/standing height		mm	3000
4.9	Height of tiller handle in drive position min./max.			-
5.1	Travel speed, laden/unladen		km/h	6/6.5
5.10	Service brake			Electromagnetic
5.11	Parking brake			-
5.2	Lifting speed, laden/unladen		m/s	0.22/0.27
5.3	Lowering speed, laden/unladen		m/s	0.31/0.25
5.6	Max. drawbar pull, laden/unladen			-
5.8	Max. gradeability, laden/unladen		%	5/8
6.1	Drive motor rating S2 60 min		kW	0.65
6.2	Lift motor rating at S3 15%		kW	2.2
6.4	Battery nominal capacity		Ah	120 135
6.4	Battery voltage		V	24
6.4.1	Battery type			Lead Acid/Li-ion
6.5	Battery weight		kg	71
6.6	Energy consumption according to DIN EN 16796		kWh/h	0.65
8.1	Type of drive control			DC
10.5	Steering design			Mini steering (left) with fingertip controls (right)
10.7	Sound pressure level at the drivers ear		dB(A)	60
15.1	Charger output current		A	15

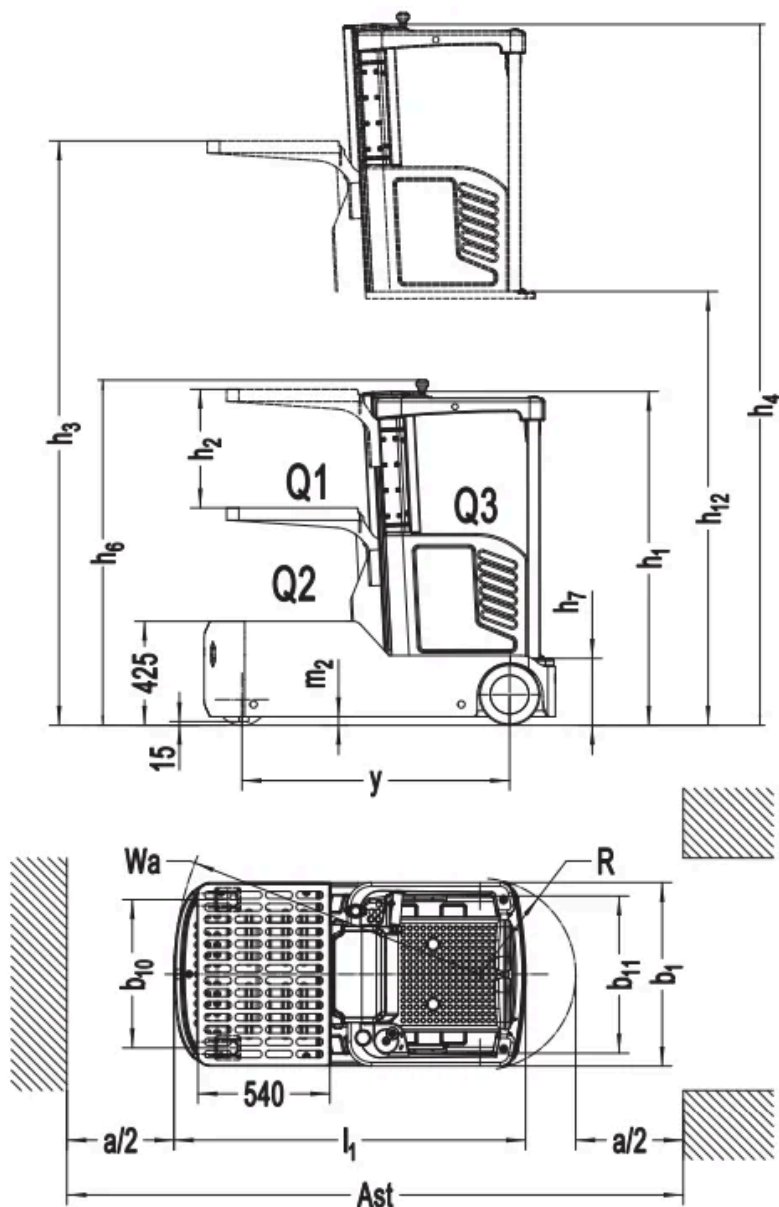

Options

ITEM	OPTIONS (optional items marked in yellow)
Load wheel type	Single
Electrostatic chain	No
Load wheel material	Rubber
Drive wheel material	PU
Battery capacity	120Ah Lead acid battery 135Ah Li-ion battery
Charger	24V-15A integrated charger for Lead acid battery 24V-30A integrated charger for Li-ion battery

ITEM	OPTIONS (optional items marked in yellow)
Battery display indicator (BDI)	With time
Buzzer	Drop buzzer Running buzzer Reversing buzzer
Guide wheel	No Yes and not customized
Castor wheels	Yes and not customized
Blue lamp	Front blue lamp
Overhead guard	No
Options	-
Tyres type	Polyurethane/Solidrubber