



EST124

ELECTRIC STACKER 1.2T

1200 kg 3613 mm 24 V AGM



Designed for shops, warehouses, and distribution centers, the EST124 is ideal for light stacking in rack systems ranging from 2.5 m to 3.6 m. Its compact design, polyurethane wheels, and turning radius of 1415 mm make it suitable for navigating narrow aisles and confined spaces. Operators benefit from ergonomic tiller control and turtle speed mode for precise and safe handling.

SPECIFICATION	REF	UNIT	VALUE
Battery type			AGM
Battery nominal capacity		Ah	80
Battery voltage		V	24
Load capacity	Q	kg	1200
Load centre distance	c	mm	600
Service weight		kg	470
Retracted mast height	h_1	mm	2067
Lift height	h_3	mm	2930
Height, mast extended	h_4	mm	3532
Overall length		mm	1706
Overall width	b_1/b_2	mm	925
Length to face of forks	l ₂	mm	556
Fork dimensions	s/e/l	mm	60/170/1150
Turning radius		Wa	1415
Operator type			Pedestrian
Load distance, centre of drive axle to fork		mm	800

Features

Strong and stable chassis

The EST124 is built with a metal cover and reinforced frame that reduces stress and deformation under heavy loads. This ensures reliability and safety during everyday stacking operations.



Medium-height stacking capability

With lift heights of up to 3.6 meters, the EST124 is ideal for warehouses with medium rack systems. Its rigid mast structure allows smooth and consistent lifting performance.

Convenient charging system

Equipped with a 24V/80Ah AGM battery and integrated 10A charger, the EST124 supports easy daily charging without the need for external equipment, ensuring flexibility and reduced downtime.





Market-proven components

Designed with components from EP's bestsellers, including tiller head, drive unit, and hydraulic system, the EST124 guarantees reliable performance, simplified parts management, and reduced maintenance costs.

VDI Chart

	SPECIFICATION	REF	UNIT	VALUE
1.4	Operator type			Pedestrian
1.5	Load capacity	Q	kg	1200
1.6	Load centre distance	c	mm	600
1.8	Load distance, centre of drive axle to fork		mm	800
1.9	Wheelbase		mm	1195
2.1	Service weight		kg	470
2.2	Axle loading, laden front/rear		kg	520/1150
2.3	Axle loading, unladen front/rear		kg	345/125
3.1	Tyre type			Polyurethane
3.2	Tyre size, front		mm	Ø210×70
3.3	Tyre size, rear		mm	Ø74×72
3.4	Additional wheels (castor wheels)		mm	Ø130×55
3.5	Wheels, number front/rear (x=drive wheels)			1x , 1/2
3.6.1	Tread width, front	b ₁₀	mm	645
3.7.1	Tread width, rear	b ₁₁	mm	418
4.0	Max lift height	H	mm	3613
4.1	Tilt of mast/fork carriage forward/backward		°	51
4.10	Height of wheel arms		mm	—
4.12	Tow coupling height		mm	24
4.15	Lowered height			90
4.19	Overall length		mm	1706
4.2	Retracted mast height	h ₁	mm	2067
4.20	Length to face of forks	l ₂	mm	556
4.21	Overall width	b ₁ /b ₂	mm	925

SPECIFICATION		REF	UNIT	VALUE
4.22	Fork dimensions	s/e/1	mm	60/170/1150
4.24	Fork carriage width		mm	680
4.25	Distance between fork-arms			570
4.26	Distance between wheel arms/loading surfaces			—
4.3	Free lift		mm	—
4.31	Ground clearance, laden, below mast		mm	—
4.32	Ground clearance, centre of wheelbase		mm	23
4.34.1	Aisle width for pallets 1000×1200 crossways		Ast	2246
4.34.2	Aisle width for pallets 800×1200 lengthways		Ast	2180
4.35	Turning radius		Wa	1415
4.4	Lift height	h ₃	mm	2930
4.5	Height, mast extended	h ₄	mm	3532
4.9	Height of tiller handle in drive position min./max.			760/1140
5.1	Travel speed, laden/unladen		km/h	4.0/4.5
5.10	Service brake			Electromagnetic
5.11	Parking brake			Electromagnetic
5.2	Lifting speed, laden/unladen		m/s	0.10/0.15
5.3	Lowering speed, laden/unladen		m/s	0.12/0.10
5.8	Max. gradeability, laden/unladen		%	3/10
6.1	Drive motor rating S2 60 min		kW	0.75
6.2	Lift motor rating at S3 15%		kW	2.2
6.4	Battery nominal capacity		Ah	80
6.4	Battery voltage		V	24
6.4.1	Battery type			AGM
6.5	Battery weight		kg	38
6.6	Energy consumption according to DIN EN 16796		kWh/h	0.57 ¹⁾
6.7	Turnover output according to VDI 2198			31.2
6.8	Turnover efficiency according to VDI 2198			51
8.1	Type of drive control			DC
10.5	Steering design			Mechanical
10.7	Sound pressure level at the drivers ear		dB(A)	74
15.1	Charger output current		A	10

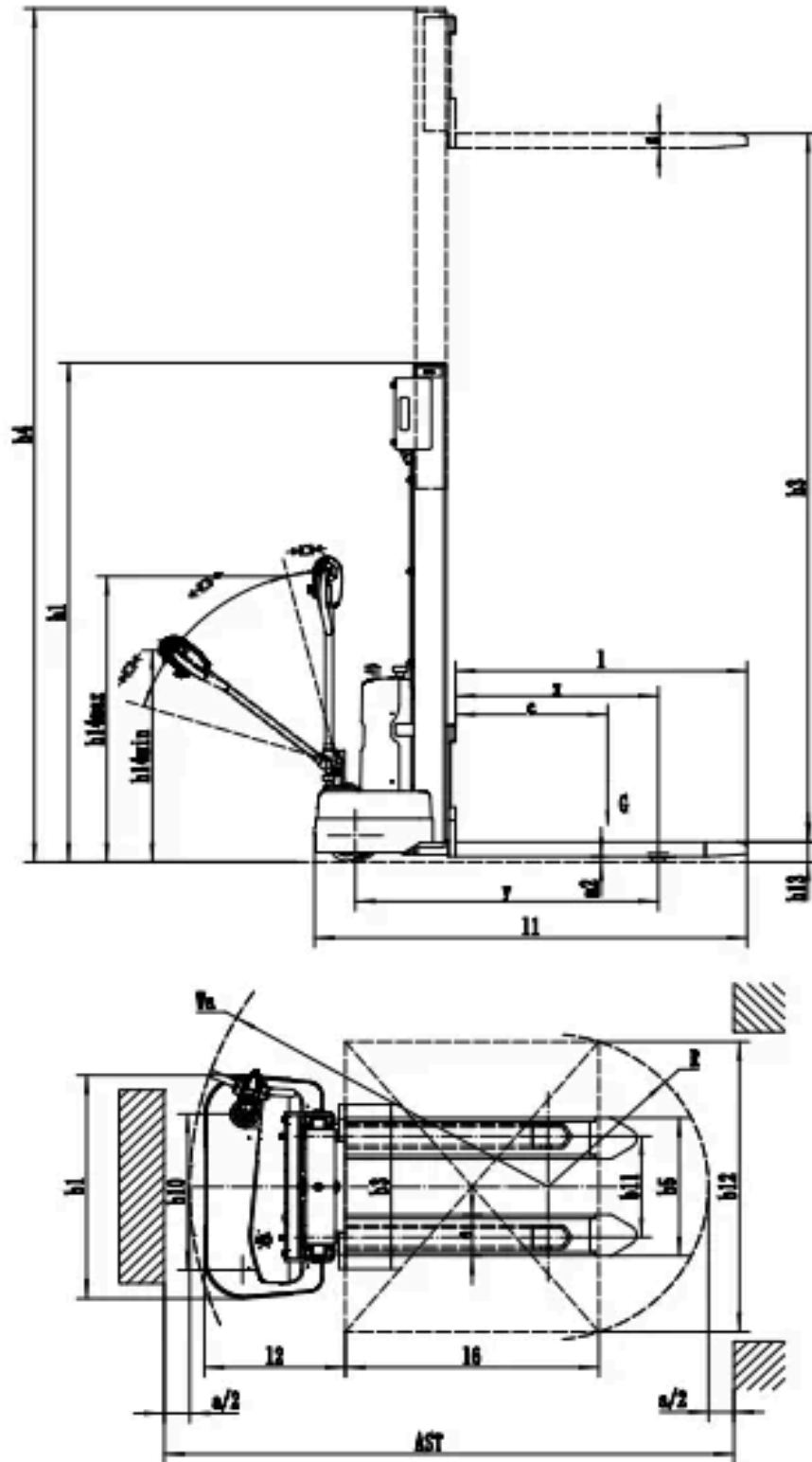

RATDE CAPACITIES GRAPH



Mast Options

MAST TYPE	LIFT HEIGHT (H3, MM)	MAST LOWERED HEIGHT (H1, MM)	MAST EXTENDED HEIGHT, NO BACKREST (H4, MM)
2-Standard Mast	2513	1817	3032
2-Standard Mast	2713	1917	3232
2-Standard Mast	3013	2067	3532
2-Standard Mast	3313	2217	3832
2-Standard Mast	3613	2367	4132

Options

ITEM	OPTIONS (optional items marked in yellow)
Fork dimension	570*1150 685*1150 570*1000 685*1000 570*1220 685*1220
Fork carriage width option	680 770
Load wheel material	PU
Drive wheel material	PU
Battery capacity	80Ah (AGM)
Charger	24V-10A integrated (AGM)

ITEM	OPTIONS (optional items marked in yellow)
Battery display indicator (BDI)	Without time
Turtle speed	Yes and not customized
Castor wheels	Yes and not customized