



# EPT20-15ET2H

## ALL-TERRAIN ELECTRIC PALLET TRUCK 1.5T

1500 kg 115 mm 24 V AGM



The EPT20-15ET2H is ideal for industries where material handling takes place on rough or uneven ground, such as construction sites, outdoor warehouses, and yards. With reinforced drive wheels and a horizontally mounted motor and brake system, it provides protection against dirt and debris while maintaining efficiency. The high ground clearance makes it safer and more stable in rugged conditions.

SPECIFICATION	REF	UNIT	VALUE
Battery type			AGM
Battery nominal capacity		Ah	72
Battery voltage		V	24
Load capacity	Q	kg	1500
Load centre distance	c	mm	600
Service weight		kg	216
Lift height	$h_3$	mm	115
Overall length		mm	1704
Overall width	$b_1/b_2$	mm	685
Length to face of forks	l2	mm	554
Turning radius		Wa	1505
Manufacturer			EP
Model designation			EPT20-15ET2H
Drive			Electric
Operator type			Pedestrian
Load distance, centre of drive axle to fork		mm	946

# Features

---

## Enhanced durability

The EPT20-15ET2H is engineered with proven components and a fully sealed structure that protects critical systems from water, dust, and debris. This rugged construction reduces wear and tear, lowers the risk of breakdowns, and ensures that the truck continues to perform reliably even in demanding outdoor environments where conventional pallet trucks would struggle.

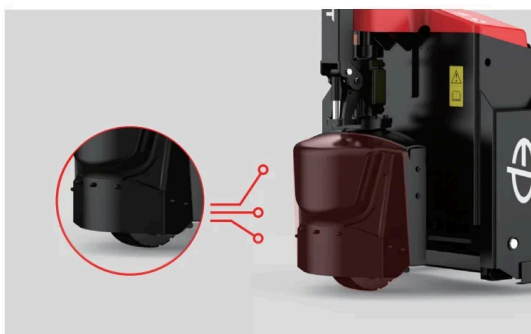

## Optimized drive system

Its horizontally mounted motor and brake not only increase ground clearance but also enhance protection against shocks and dirt. Combined with a reinforced rubber drive wheel, the system delivers excellent slip resistance and wear durability. These improvements guarantee safer operation on uneven surfaces and reduce maintenance needs, making it a dependable choice for heavy-duty tasks.

## Outdoor-ready design

With increased ground clearance and robust chassis components, the EPT20-15ET2H is specifically adapted for rough or uneven terrain. Operators can use it with confidence in construction sites, yards, and outdoor warehouses. This design expands the application range of the pallet truck beyond traditional smooth-floor environments, giving businesses greater flexibility.



## AGM battery with integrated charger

Equipped with a 24V/65Ah AGM battery as standard, the truck supports opportunity charging through its integrated 24V-10A charger, making it simple and convenient to keep powered throughout the day. For operations requiring longer runtime, an 85Ah battery option is available, ensuring the truck adapts easily to both light-duty and intensive outdoor shifts without performance loss.

# VDI Chart

	SPECIFICATION	REF	UNIT	VALUE
1.1	Manufacturer			EP
1.2	Model designation			EPT20-15ET2H
1.3	Drive			Electric
1.4	Operator type			Pedestrian
1.5	Load capacity	Q	kg	1500
1.6	Load centre distance	c	mm	600
1.8	Load distance, centre of drive axle to fork		mm	946
1.9	Wheelbase		mm	1301
2.1	Service weight		kg	216
2.2	Axle loading, laden front/rear		kg	724/1468
2.3	Axle loading, unladen front/rear		kg	165/40
3.1	Tyre type			Rubber/PU
3.2	Tyre size, front		mm	210x70
3.3	Tyre size, rear		mm	80x61 / 105x88
3.5	Wheels, number front/rear (x=drive wheels)			1x — /4
3.7.1	Tread width, rear	$b_{11}$	mm	410 (535)
4.0	Max lift height	H	mm	115
4.19	Overall length		mm	1704
4.20	Length to face of forks	l <sub>2</sub>	mm	554
4.21	Overall width	$b_1/b_2$	mm	685
4.34.1	Aisle width for pallets 1000×1200 crossways		Ast	2307
4.34.2	Aisle width for pallets 800×1200 lengthways		Ast	2179
4.35	Turning radius		Wa	1505
4.4	Lift height	$h_3$	mm	115
5.1	Travel speed, laden/unladen		km/h	4 / 4.5
5.10	Service brake			Electromagnetic
5.2	Lifting speed, laden/unladen		m/s	0.027 / 0.038
5.3	Lowering speed, laden/unladen		m/s	0.059/0.039
5.8	Max. gradeability, laden/unladen		%	5 / 16
6.1	Drive motor rating S2 60 min		kW	0.75
6.2	Lift motor rating at S3 15%		kW	0.8
6.4	Battery nominal capacity		Ah	72

	SPECIFICATION	REF	UNIT	VALUE
6.4	Battery voltage		V	24
6.4.1	Battery type			AGM
6.5	Battery weight		kg	34
8.1	Type of drive control			DC
10.5	Steering design			Mechanical
10.7	Sound pressure level at the drivers ear		dB(A)	<74

## VDI Drawing

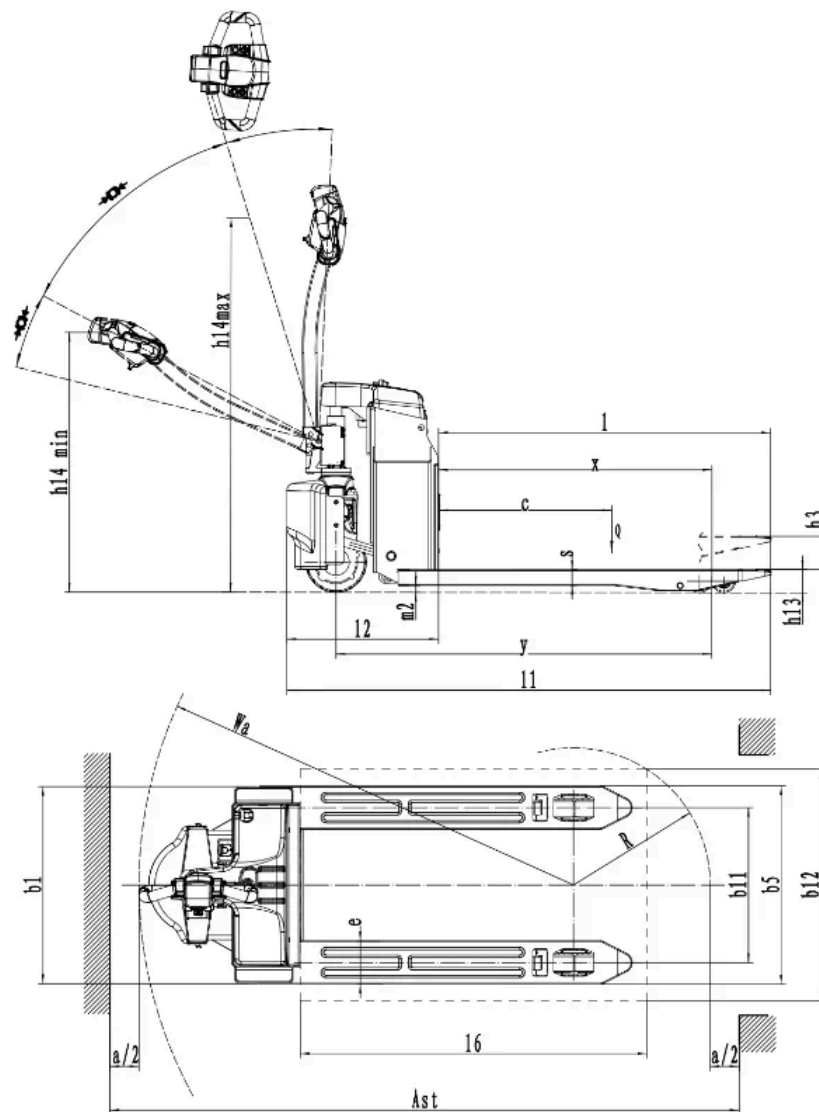

# Options

ITEM	OPTIONS (optional items marked in yellow)
Fork dimension	560*1150   560*800   560*1000   560*1220   560*1300   560*1400   560*1500   560*1600   560*1800   560*2000   685*800   685*1000   685*1150   685*1220   685*1300   685*1400   685*1500   685*1600   685*1800   685*2000
Fork lowered height	80
Load wheel type	Double   Single
Load wheel material	PU
Drive wheel material	Rubber   PU
Battery capacity	72Ah AGM   85Ah AGM
Charger	24V-10A Integrated charger
Battery display indicator (BDI)	With hourmeter
Buzzer	Yes and not customized
Turtle speed	Yes and not customized
Castor wheels	No   Yes and not customized