



EFX2 -251

LI-ION COUNTERBALANCE FORKLIFT TRUCK 2.5T

2500 kg 4800 mm 80 V Li-Ion



The EFL X2 Series is designed for operators seeking a simple, budget-friendly, and sustainable alternative to internal combustion and second-hand forklifts. Its robust chassis and high ground clearance allow smooth operation on uneven or outdoor surfaces, while the proportional lifting system ensures precision for warehouse stacking. Ideal for rental fleets, light- to medium-duty logistics, retail warehouses, and general manufacturing, it's the perfect entry-level Li-ion forklift for versatile daily use.

SPECIFICATION	REF	UNIT	VALUE
Battery type			Li-Ion
Battery nominal capacity		Ah	100
Battery voltage		V	80
Load capacity	Q	kg	2500
Load centre distance	c	mm	500
Service weight		kg	4116
Retracted mast height	h_1	mm	2090
Lift height	h_3	mm	3000
Height, mast extended	h_4	mm	4025
Overall length		mm	3598
Overall width	b_1/b_2	mm	1154
Length to face of forks	l2	mm	2528
Fork dimensions	s/e/l	mm	40×122×1070
Turning radius		Wa	2258
Manufacturer			EP
Model designation			EFX2 -251

Features

Efficient PMSM motor technology

The PMSM drive and lift motors deliver consistent torque and energy efficiency. Operators experience smoother lifting, improved responsiveness, and up to 15% energy savings compared to conventional AC systems.



Maintenance-free 80V Li-ion system

Equipped with an 80V/100Ah Li-ion battery and a 35A onboard charger, the EFL X2 Series supports convenient opportunity charging and requires no battery maintenance. The Li-ion system extends runtime and enhances energy reliability for daily operations.

Comfortable and ergonomic operation

An adjustable steering column, ample legroom, and a suspended seat with safety belt ensure operator comfort. The proportional lift system offers precise stacking control, ideal for tight warehouse layouts or sensitive loads.



Versatile for indoor and outdoor use

A waterproof chassis, pneumatic tires, and high ground clearance make the EFL X2 Series suitable for all working environments, from factory floors to outdoor yards. The truck's simple design and durability minimize downtime and operational cost.

VDI Chart

	SPECIFICATION	REF	UNIT	VALUE
1.1	Manufacturer			EP

SPECIFICATION		REF	UNIT	VALUE
1.2	Model designation			EFX2 -251
1.3	Drive			Electric
1.4	Operator type			Seated
1.5	Load capacity	Q	kg	2500
1.6	Load centre distance	c	mm	500
1.8	Load distance, centre of drive axle to fork		mm	495
1.9	Wheelbase		mm	1650
2.1	Service weight		kg	4116
2.2	Axle loading, laden front/rear		kg	5813/803
2.3	Axle loading, unladen front/rear		kg	1805/2311
3.1	Tyre type			Solidrubber
3.2	Tyre size, front		mm	7.00-12
3.3	Tyre size, rear		mm	18X7-8
3.5	Wheels, number front/rear (x=drive wheels)			2x/2
3.6.1	Tread width, front	b_{10}	mm	975
3.7.1	Tread width, rear	b_{11}	mm	955
4.0	Max lift height	H	mm	4800
4.1	Tilt of mast/fork carriage forward/backward		°	6/10
4.12	Tow coupling height		mm	445
4.19	Overall length		mm	3598
4.2	Retracted mast height	h_1	mm	2090
4.2.1	Overall height			4025
4.20	Length to face of forks	l ₂	mm	2528
4.21	Overall width	b_1/b_2	mm	1154
4.22	Fork dimensions	s/e/l	mm	40×122×1070
4.23	A,B Fork carriage class/type A, B			2A
4.24	Fork carriage width		mm	1040
4.3	Free lift		mm	135
4.31	Ground clearance, laden, below mast		mm	110
4.32	Ground clearance, centre of wheelbase		mm	150
4.34.1	Aisle width for pallets 1000×1200 crossways		Ast	3953
4.34.2	Aisle width for pallets 800×1200 lengthways		Ast	4153
4.35	Turning radius		Wa	2258
4.4	Lift height	h_3	mm	3000

	SPECIFICATION	REF	UNIT	VALUE
4.5	Height, mast extended	h_4	mm	4025
4.7	Height of overhead guard (cabin)		mm	2170
4.8	Seat height/standing height		mm	1100
5.1	Travel speed, laden/unladen		km/h	11/12
5.10	Service brake			Hydraulic
5.11	Parking brake			Mechanical
5.2	Lifting speed, laden/unladen		m/s	0.29/0.36
5.3	Lowering speed, laden/unladen		m/s	0.4/0.43
5.8	Max. gradeability, laden/unladen		%	15/15
6.1	Drive motor rating S2 60 min		kW	8
6.2	Lift motor rating at S3 15%		kW	16
6.4	Battery nominal capacity		Ah	100
6.4	Battery voltage		V	80
6.4.1	Battery type			Li-Ion
8.1	Type of drive control			PMSM
10.5	Steering design			Hydraulic
10.7	Sound pressure level at the drivers ear		dB(A)	<74
15.1	Charger output current		A	8

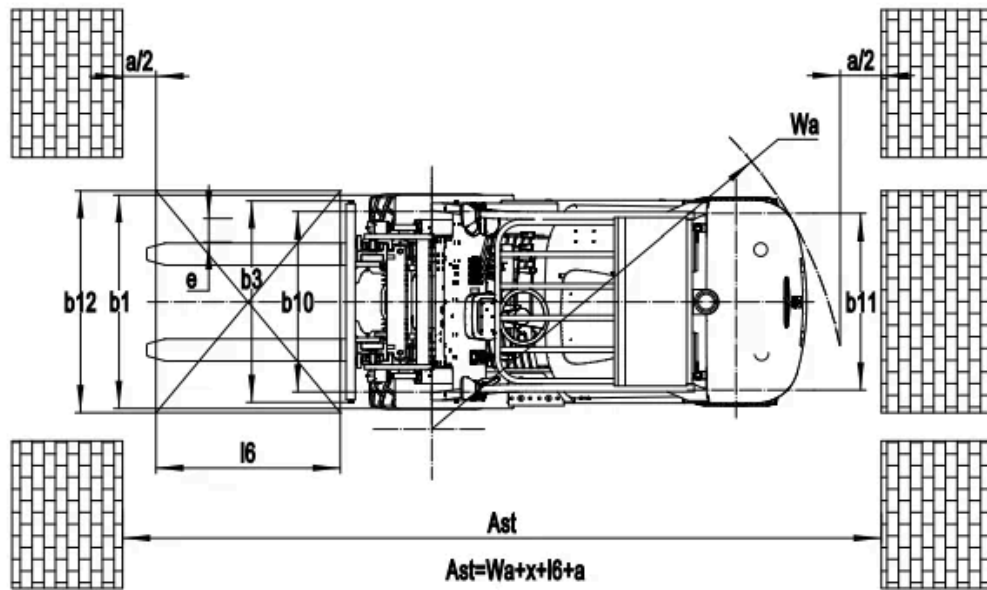
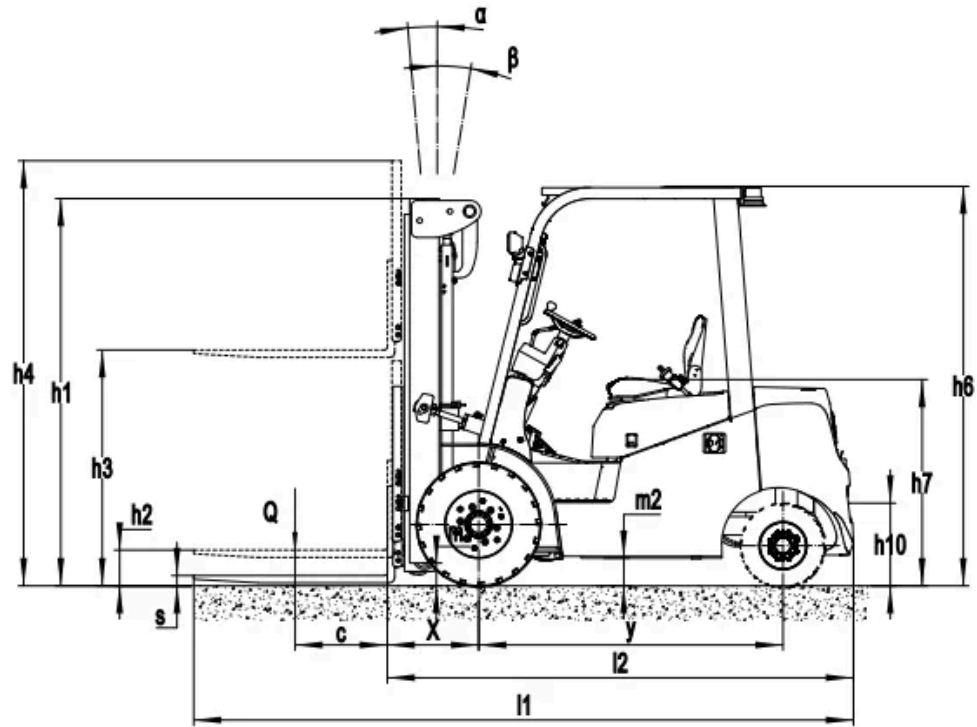

RATED CAPACITIES AND LOAD CENTERES GRAPH

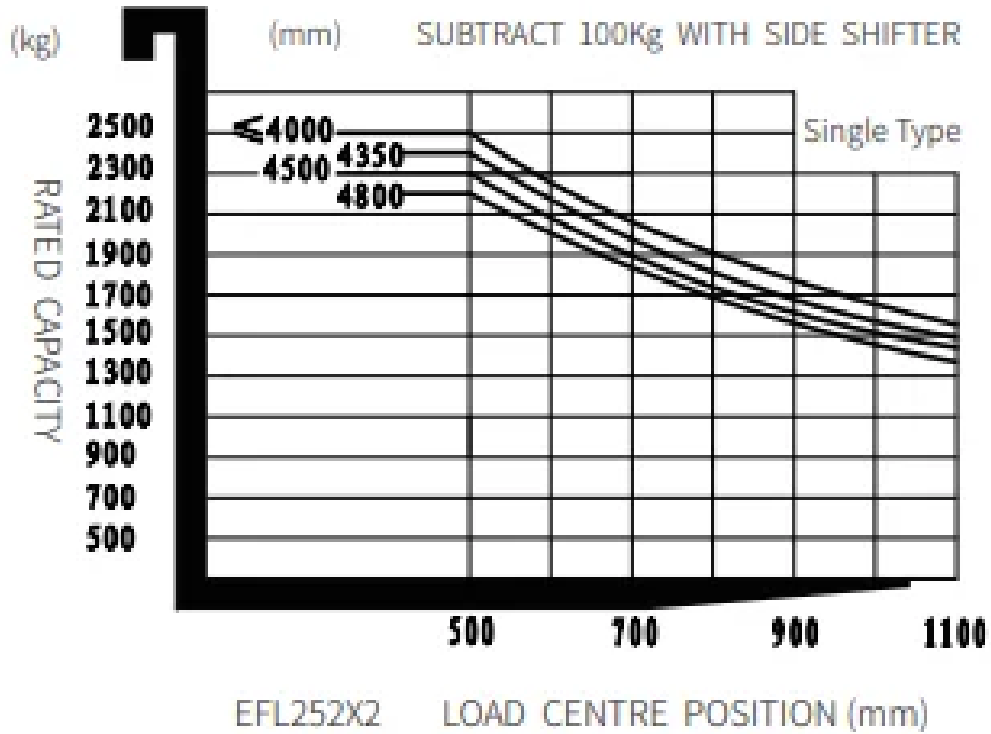

Mast Options

MAST TYPE	LIFT HEIGHT (H3, MM)	MAST LOWERED HEIGHT (H1, MM)	HEIGHT, MAST EXTENDED, NO SHELVING (H4, MM)	HEIGHT, MAST EXTENDED, WITH SHELVING (H4, MM)	HEIGHT, FREE LIFT, NO SHELVING (H2, MM)	HEIGHT, FREE LIFT, WITH SHELVING (H2, MM)
2-Standard Mast	3000	2090	3565	4025	120	120
2-Standard Mast	3300	2240	3865	4325	120	120
3-Free Mast	4500	2115	5065	5525	1550	1090
3-Free Mast	4800	2220	5365	5825	1655	1195

Options

ITEM	OPTIONS (optional items marked in yellow)
Fork dimension	122*40*920 122*40*1070 122*40*1150 122*40*1220 122*40*1370 122*40*1500 122*40*1600 122*40*1700 122*40*1820 122*40*1900 122*40*2000 122*40*2200
Fork carriage width option	1040mm

ITEM	OPTIONS (optional items marked in yellow)
Backrest height	1025mm
Seat type	Regular+safety belt logic switch Suspension+safety belt logic switch Suspension seat with armrest + safety belt switch Comfortable + safety belt logic switch
Attachments	No Built-in sidsifter External shifter
Traction pin	Yes and not customized
Electrostatic chain	Yes and not customized
Front wheel material	Pneumatic Normal solid Non-marking solid
Rear wheel material	Pneumatic Normal solid Non-marking solid
Battery capacity	80V100AH 80V150AH 80V230AH 80V280AH
Charger	80V35A(integrated) 80V60A (External) 80V60A(integrated) 80V100A (External,only for 80V230AH&280AH battery)
Battery display indicator (BDI)	With hourmeter
Area warning lamp	No Both sides Both sides and rear
Rearview mirror	One in front Two on sides
Buzzer	Yes and not customized
OPS system	Yes and not customized No
USB interface	Yes and not customized
Telematics	Yes and not customized No
Front lamp	LED
Rear lamp	No LED
Cabin	No Upgrade half cabin Full cabin
Proportional lift system	Yes and not customized
Forks tilt forward and backward	Yes and not customized
Overhead guard	Standard overhead guard s:Yes and customizable
Special AUS/NZ options	No Yes and not customized