



## HIGH CAPACITY ELECTRIC COUNTERBALANCED FORKLIFT 5.0T

7000 mm 309 V Li-Ion



### Compact and Mighty

EFL403-553 HV offer more compact sizes while delivering enhanced performance over low-voltage forklift models. Their single front wheel design allows maneuverability in tighter spaces, making them ideal for industries like steel manufacturing, automotive, and heavy machinery production where space can be limited. With high-voltage Li-ion batteries, EFL403-553 can endure operating hours up to 6 hours. The 20-25% gradeability enables them to handle rough terrain and ramps with ease, making them suitable for outdoor applications with ease.

SPECIFICATION	REF	UNIT	VALUE
Battery type			Li-Ion
Battery nominal capacity		Ah	173
Battery voltage		V	309
Load centre distance	c	mm	500
Service weight		kg	7350
Retracted mast height	h <sub>1</sub>	mm	2250
Lift height	h <sub>3</sub>	mm	3000
Height, mast extended	h <sub>4</sub>	mm	4177/3835
Overall length		mm	4130
Overall width	b <sub>1</sub> /b <sub>2</sub>	mm	1495
Length to face of forks	l <sub>2</sub>	mm	3060
Fork dimensions	s/e/l	mm	55x150x1070
Turning radius		Wa	2730
Operator type			Seated
Load distance, centre of drive axle to fork		mm	550
Wheelbase		mm	2000

# Features

---

## High Performance: High speed and high gradeability

High-voltage Li-ion batteries enable more power delivery to motors, improving acceleration and travel speeds for high-capacity trucks. PMSMs complement this with rapid response times, swiftly reaching required speeds and torques. This combination of PMSM and high voltage can provide stable and strong power output, which further gives high-capacity trucks excellent climbing capabilities ensuring that the forklift can cope with various applications with ease.

The high-voltage model offers a 1.5-2 times performance improvement over the low-voltage model. Taking the 10-ton model as an example:

100% improvement in travel speed for high voltage models in laden and unladen conditions.

The high-voltage model demonstrates a 45% faster lifting speed.

100% improvement in gradeability when unladen, 45% improvement when laden for high voltage models.

## Energy Efficiency: extended runtime and fast charging

High-voltage Li-ion batteries have high energy density and can store more electrical energy within a compact volume. High-voltage systems consume less energy and provide longer battery running time comparing low-voltage systems. Notably, these high-voltage Li-ion batteries boast an impressive cycle life of up to 4000 cycles, ensuring long-term durability and minimizing the need for battery replacements.

The PMSMs incorporate advanced control technology to optimize motor efficiency. Unlike traditional AC motors, PMSMs have higher energy conversion efficiency and reduce energy waste. This means that high-capacity trucks can work continuously for prolonged hours at lower costs.

Equipped with fast charging capabilities, high-capacity trucks offer a remarkable charging experience. The high-voltage models are compatible with vehicle-grade charging stations and support 1C charging rating, allowing them to be fully charged in as fast as 1-1.2 hours. This minimizes downtime and maximizes productivity, making it ideal for multi-shift operations

Lithium batteries present considerably lower charging costs than fuel expenses. The integration of high-voltage and PMSM technology achieves up to 15% greater electricity savings versus traditional lithium and AC technology configurations. This significantly reduces long-term energy consumption costs.



## Safety Assured: Battery, motor protection, monitoring and mast buffering

Both high-voltage lithium batteries and PMSM employ multiple protective measures to ensure safe operations including overcharge protection, over-temperature monitoring, short-circuit protection, etc. minimizing the risk of potential hazards and maximizing operational safety.

The central controlling module- VCU (Vehicle Control Unit) extends the safety of the high-voltage forklifts. VCU provides precise control and real-time monitoring of critical parameters to ensure the truck operates within safe limits.

It also features turn speed control, which adjusts the forklift's speed based on the turning angle, ensuring stability during turns. An over-speed alarm alerts the operator if the forklift exceeds the safe speed limit.\*

The high-capacity forklift mast is equipped with a hydraulic buffering system that ensures smooth lifting and lowering of loads. With controlled deceleration, the fork movement is smooth with no abrupt stops that could damage the load or cause operator discomfort. This feature enhances operational safety and prolongs the lifespan of the mast components.



## Smart and reliable strategy for thermal management

The high-capacity trucks utilize three distinct cooling systems to ensure optimal performance and reliability. Specifically, two water cooling systems are employed for the motor and the battery, while an oil cooling system is dedicated to the hydraulics system.

The water cooling systems provide superior cooling performance, preventing the truck from overheating even under the most demanding conditions or in the heat of summer. Water's higher heat transfer capacity compared to air allows it to dissipate heat more efficiently from critical components like the motor and battery. This efficient heat dissipation helps maintain the battery temperature around 30~35 °C , protecting these vital components from overheating and potential damage or failure. Consequently, this enhances the overall reliability and longevity of the high-capacity trucks.

Additionally, water cooling systems typically operate with less noise compared to air cooling systems that rely on high-speed fans. This noise reduction is particularly beneficial in applications where a quieter operation is desirable, such as in urban areas or indoor facilities.

The oil cooling system, on the other hand, is used for the hydraulics system. This system ensures that the hydraulic components remain within optimal temperature ranges, thereby maintaining their efficiency and preventing overheating. By effectively managing the temperature of the hydraulics system, the oil cooling system contributes to the smooth and reliable operation of the truck's hydraulic functions.

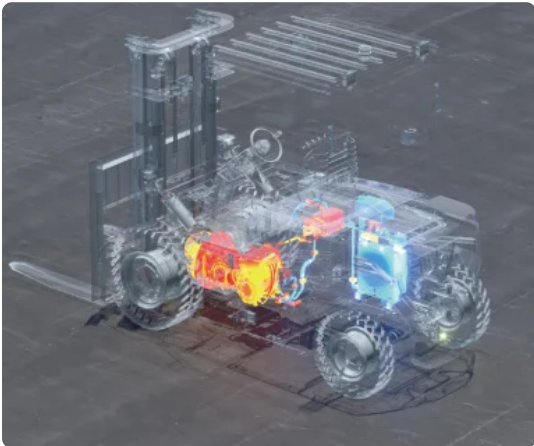

## Low maintenance: Longer battery life span

Operating at a higher voltage allows the battery to be designed with fewer individual cells. With fewer components and a simpler design, the risk of battery failure is lowered.

Thanks to advanced BMS (Battery Management System) which helps to regulate and monitor high-voltage battery, these batteries tend to have a longer life than low-voltage lithium batteries, reducing the need of battery replacement.

The brushless, simple rotor design of PMSM eliminates mechanical wear from brushes and commutators. This durable, low-friction construction requires minimal periodic maintenance, reducing associated labor costs and downtime.

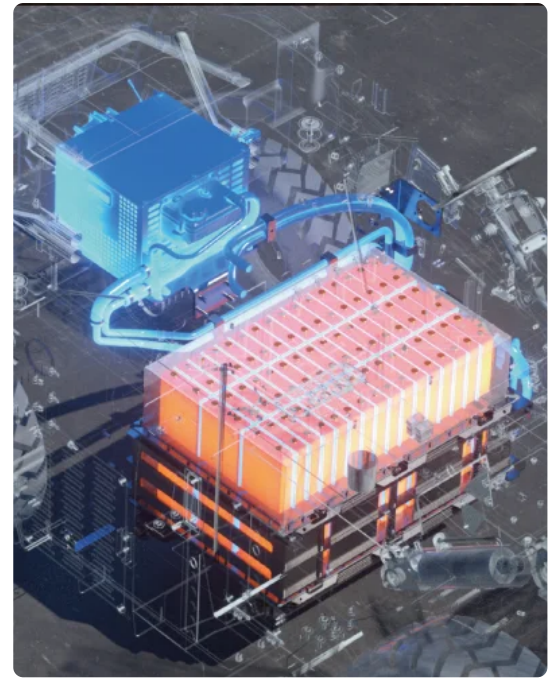

## Sustainability : Zero emissions for cleaner environment

As fully electric trucks powered by lithium-ion batteries, these forklifts produce zero emissions during operation, eliminating exposure to toxic fumes like carbon monoxide and nitrogen oxides. Unlike lead-acid batteries which can leak corrosive acid, lithium-ion batteries do not risk hazardous spills. The high-capacity li-ion trucks contribute to a cleaner and safer indoor working environment without compromising handling capabilities.

## Strong adaptability adaptable to harsh outdoor weather conditions

Experience uninterrupted productivity through rain, puddles, and damp conditions with the overall IPX4 rating. Plus an exceptional IP67 rating for high-voltage components. Engineered to withstand harsh temperature, high-capacity trucks offer an ambient temperature range of -20 °C ~40 °C allowing them to perform no matter climate.

Battery heating when charging comes as a standard function for high capacity models, which is activated when the surrounding temperature is below zero to always offer an optimal temperature range for efficient and safe charging even in cold weather conditions.



The dual front wheels is a standard configuration on several models offering a wider base of support, which greatly improves the forklift's stability. Considering the capacity loads of the high-capacity trucks, the weight of the load is more evenly distributed across a larger surface area. The increased ground contact area provided by the dual wheels enhances traction. This is particularly beneficial in environments where the floor may be slippery or uneven while operating outdoors, ensuring that the forklift can maintain a firm grip and operate safely. This not only helps in maintaining balance but also minimizes the stress on individual tires, extending the lifespan of the tires.

## Great support for clients' investment: After-sales Service

Remote/Online Services:

Telematics technology enables remote monitoring of battery conditions, performance status, and other critical parameters for forklifts. Additionally, production, technical, and after-sales experts are available around the clock to provide prompt and comprehensive solutions for any maintenance issues through virtual support.

Physical Services:

Comprehensive manuals and supporting documents are provided for all forklift models. In case of breakdowns or replacements, spare parts are swiftly delivered to the clients' locations by global subsidiaries or domestic inventory, minimizing operational disruptions caused by equipment downtime.

## VDI Chart

SPECIFICATION	REF	UNIT	VALUE
1.4	Operator type		Seated

SPECIFICATION		REF	UNIT	VALUE
1.6	Load centre distance	c	mm	500
1.8	Load distance, centre of drive axle to fork		mm	550
1.9	Wheelbase		mm	2000
2.1	Service weight		kg	7350
2.2	Axle loading, laden front/rear		kg	11064/1286
2.3	Axle loading, unladen front/rear		kg	3439/3911
3.1	Tyre type			pneumatic
3.2	Tyre size, front		mm	300-15-20PR
3.3	Tyre size, rear		mm	7.00-12-12PR
3.5	Wheels, number front/rear (x=drive wheels)			2x/ 2
3.6.1	Tread width, front	$b_{10}$	mm	1176
3.7.1	Tread width, rear	$b_{11}$	mm	1190
4.0	Max lift height	H	mm	7000
4.1	Tilt of mast/fork carriage forward/backward		°	6/12
4.12	Tow coupling height		mm	640
4.19	Overall length		mm	4130
4.2	Retracted mast height	$h_1$	mm	2250
4.20	Length to face of forks	l2	mm	3060
4.21	Overall width	$b_1/b_2$	mm	1495
4.22	Fork dimensions	s/e/l	mm	55x150x1070
4.23	A,B Fork carriage class/type A, B			3A
4.24	Fork carriage width		mm	1380
4.3	Free lift		mm	155
4.31	Ground clearance, laden, below mast		mm	150
4.32	Ground clearance, centre of wheelbase		mm	180
4.34.1	Aisle width for pallets 1000×1200 crossways		Ast	4550
4.34.2	Aisle width for pallets 800×1200 lengthways		Ast	4550
4.35	Turning radius		Wa	2730
4.4	Lift height	$h_3$	mm	3000
4.5	Height, mast extended	$h_4$	mm	4177/3835
4.7	Height of overhead guard (cabin)		mm	2400
4.8	Seat height/standing height		mm	1290
5.1	Travel speed, laden/unladen		km/h	24/25
5.10	Service brake			Hydraulic

SPECIFICATION		REF	UNIT	VALUE
5.11	Parking brake			Mechanical
5.2	Lifting speed, laden/unladen		m/s	0.38/0.48
5.3	Lowering speed, laden/unladen		m/s	0.41/0.42
5.8	Max. gradeability, laden/unladen		%	24/26
6.1	Drive motor rating S2 60 min		kW	30
6.2	Lift motor rating at S3 15%		kW	27.8
6.4	Battery nominal capacity		Ah	173
6.4	Battery voltage		V	309
6.4.1	Battery type			Li-Ion
6.5	Battery weight		kg	473
8.1	Type of drive control			PMSM
10.5	Steering design			Hydraulic

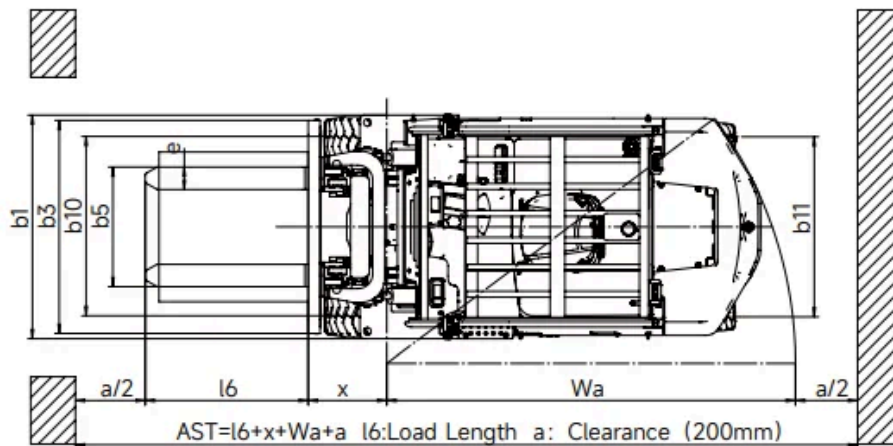
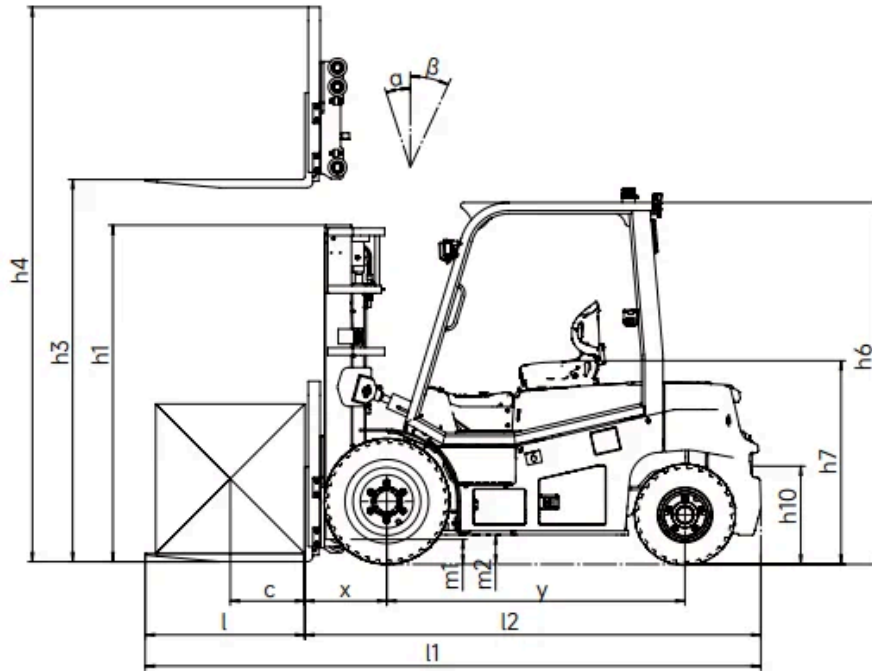

## EFL503-HV RATED CAPACITIES AND LOAD CENTERES GRAPH

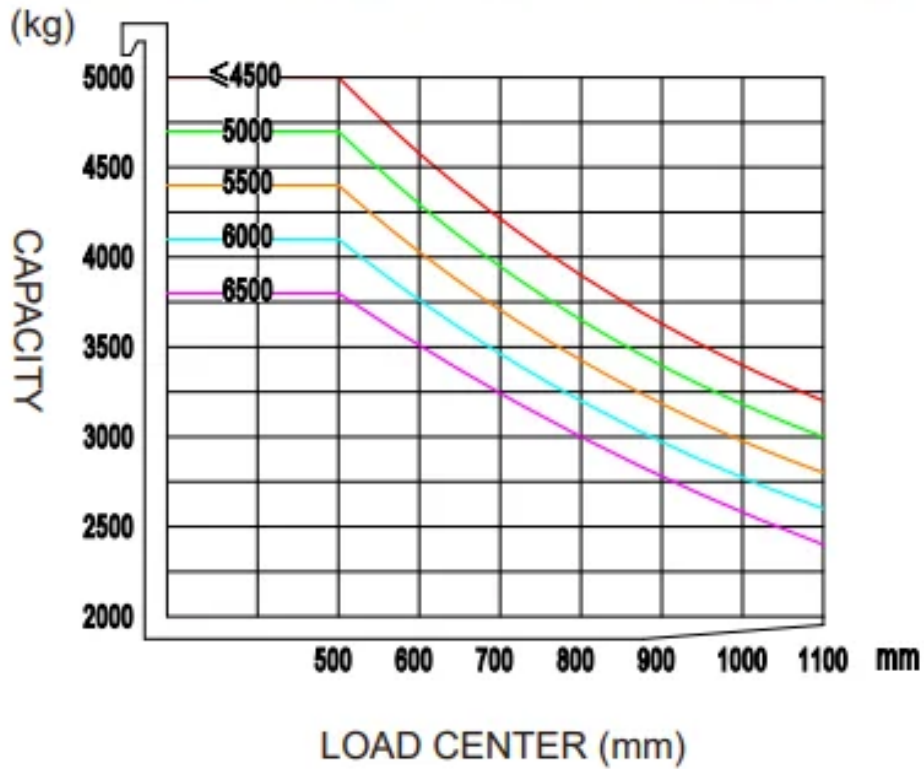

## Mast Options

MAST TYPE	LIFT HEIGHT (H3, MM)	MAST LOWERED HEIGHT (H1, MM)	MAST EXTENDED HEIGHT, NO BACKREST (H4, MM)	MAST EXTENDED HEIGHT, WITH BACKREST (H4, MM)	FREE LIFT HEIGHT, NO BACKREST (H2, MM)	FREE LIFT HEIGHT, WITH BACKREST (H2, MM)
2-Standard Mast	3000	2250	3835	4177	155	155
2-Standard Mast	3500	2500	4335	4677	155	155
2-Standard Mast	4000	2750	4835	5177	155	155
2-Standard Mast	4500	3050	5385	5677	155	155
2-Standard Mast	5000	3300	5885	6177	155	155
2-Standard Mast	5500	3600	6435	7177	155	155
2-Standard Mast	6000	3850	6935	7177	155	155
2-Standard Mast	6500	4150	7485	7677	155	155
2-Free Mast(Tentative)	3000	2250	-	4244	860	1364
2-Free Mast(Tentative)	3500	2500	-	4744	1110	1614

MAST TYPE	LIFT HEIGHT (H3, MM)	MAST LOWERED HEIGHT (H1, MM)	MAST EXTENDED HEIGHT, NO BACKREST (H4, MM)	MAST EXTENDED HEIGHT, WITH BACKREST (H4, MM)	FREE LIFT HEIGHT, NO BACKREST (H2, MM)	FREE LIFT HEIGHT, WITH BACKREST (H2, MM)
2-Free Mast(Tentative)	4000	2750	-	5244	-	-
3-Free Mast	4500	2247	5242	5677	1530	1096
3-Free Mast	5000	2413	5742	6177	1697	1263
3-Free Mast	5500	2580	6242	6677	1864	1430
3-Free Mast	6000	2797	6792	7177	2031	1647
3-Free Mast	6500	2963	7292	7677	2198	1814
3-Free Mast	7000	3130	7792	8177	2365	1981

## Options

ITEM	OPTIONS (optional items marked in yellow)
Fork dimension	1070mm forks (500mm LC) /1220mm forks (600mm LC)   Customized fork length/non-standard accessories   Hook-on forks
Fork carriage width option	1424mm   Customized fork carriage width
Backrest height	Fork backrest with hook on type fork   Customized fork backrest
Seat type	Grammer MSG65-531 mechanical suspension seat with armrest + safety belt switch   Upgrade mechanical suspension seat with armrest + headrest + safety belt switch
Attachments	Hook-on sideshifter   Hook-on fork positioner with sideshifter   Fork positioner: Pin-type forks
Battery capacity	309V173Ah LFP battery
Charger	20kw (3 phase AC 370V-460V, 50-60HZ, 32A plug)   40kw (3 phase AC 370V-460V, 50-60HZ, 63A plug)
Buzzer	Yes
Camera	Reversing radar/reversing camera/reversing radar and camera
OPS system	Yes
USB interface	USB interface 24V
Telematics	Yes
Cabin	Basic half-cabin: front windshield, front wiper (including sprinkler), roof   Upgrade half-cabin: basic half-cabin, rear windshield, rear wiper   Basic full cabin: upgrade half-cabin, left and right doors, defogging device   Upgrade full cabin: basic full cabin, air conditioner
Overhead guard	Standard overhead guard

ITEM	OPTIONS (optional items marked in yellow)
Turn speed control	Optional
Heating system during lithium battery charging	Yes
Rear armrest horn	Yes
Mast lifting and lowering buffer	Yes
Lighting package	LED front working light, turn signal light, market light, LED rear working light, strobe warning light   LED working lights on mast   Rotating warning light / rotating buzzer warning light   Rear/rear and front blue lamp   Front fog light   Customized area warning light
Mechanical lever	Yes
Options	Solid tyres / non-marking tyres   Cigarette lighter socket 12V5A   Adjustable overspeed alarm