



EFL353S

LI-ION COUNTERBALANCE FORKLIFT 3.5T

3500 kg 6000 mm 80 V Li-Ion



The EFL 3 Series is engineered for intensive logistics, production, and material handling environments. Ideal for warehouses, manufacturing plants, and distribution centers, it performs reliably on uneven outdoor terrain thanks to its large solid rubber tires and high ground clearance. Optional cabins, heating systems, and a fully enclosed design extend its usability to all-weather operations, ensuring year-round productivity across multiple industries.

SPECIFICATION	REF	UNIT	VALUE
Battery type			Li-Ion
Battery nominal capacity		Ah	280
Battery voltage		V	80
Load capacity	Q	kg	3500
Load centre distance	c	mm	500
Service weight		kg	4625
Retracted mast height	h_1	mm	2070
Lift height	h_3	mm	3000
Height, mast extended	h_4	mm	4095
Overall length		mm	3688
Overall width	b_1/b_2	mm	1210
Length to face of forks	l2	mm	2618
Fork dimensions	s/e/l	mm	50X122X1070
Turning radius		Wa	2405
Operator type			Seated
Load distance, centre of drive axle to fork		mm	486

Features

Higher performance for productivity boost

Max travel speed 19/20km/h to cover diverse intralogistics application needs.

Max battery capacity 80V/560Ah and max charging current 200A for longer uptime and fast charging.

Max gradeability 22/28% to deliver better stability on ramps.

Max lifting speed 0.48/0.54m/s for greater efficiency.



The truck structure integrates aesthetics and practical design

Both practicality and beauty are reflected in the design of the new EFL series. It inherits the robust chassis of the T8 IC truck series and features a more streamlined and compact counterweight, to better fit in confined space. Plus, the rain-proofed charging port protects the port from water splash and ensures charging safety.

Lithium technology to replace internal combustion engine

The lithium technology has proven itself as an emission-free and maintenance-free alternative to diesel. The new generation of EFL series handles loads with consistently high performance due to opportunity charging even for the most demanding applications.



Multi-functions for safe operation and easy fleet management

The new EFL series is equipped with a variety of functional configurations, such as OPS system, Telematics and card system, which not only takes security as priority but als

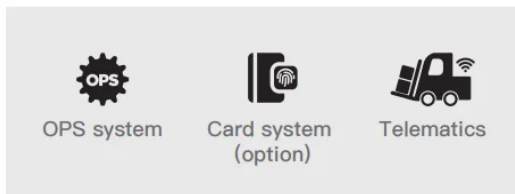

Ergonomic improvements for comfortable operation

The workspace of the new EFL series is more spacious with a simplified panel and a comfortable pedal. The series features a new LED display that clearly shows speed, working hours, battery status, mileage and parking status so the operator can easily grasp the truck conditions just with a glance

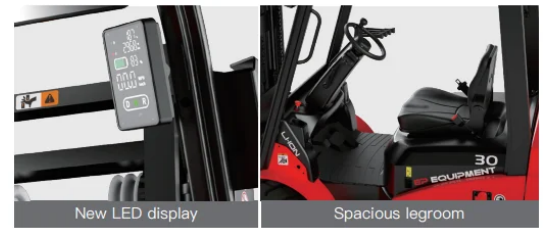

New LED display

Spacious legroom

Joystick option available for fatigue-free work

The S/P version can be equipped with hydraulic joystick controls instead of mechanical levers. Positioned at the end of the armrest operations can be done just with fingers, increasing the operator ergonomics through the following controls: all fork hydraulic control including the 4th way, driving direction (F-N-B), horn, emergency stop button.



Outdoor behavior with high-visibility closed roof and cabin options

The bolted overhead guard is fitted as standard with a new closed roof made of tempered glass and flat high-strength steel bars, offering the highest visibility in the category. It enables safe load handling at all heights and increases productivity by increasing the number of pallet movements. Outdoor performance can be enhanced with cabin options such as front windshield, semi-cab, full cabin, heater and A/C. For added flexibility, the front windshield and semi cabin can be offered in a retrofit kit for easy installation by dealers.

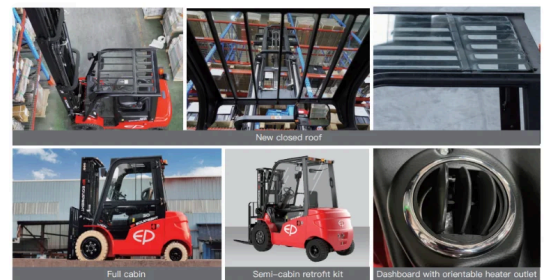

Full cabin

Semi-cabin retrofit kit

Dashboard with orientable heater outlet

VDI Chart

	SPECIFICATION	REF	UNIT	VALUE
1.4	Operator type			Seated
1.5	Load capacity	Q	kg	3500
1.6	Load centre distance	c	mm	500

	SPECIFICATION	REF	UNIT	VALUE
1.8	Load distance, centre of drive axle to fork		mm	486
1.9	Wheelbase		mm	1740
2.1	Service weight		kg	4625
2.2	Axle loading, laden front/rear		kg	7355/770
2.3	Axle loading, unladen front/rear		kg	1870/2755
3.1	Tyre type			Solidrubber
3.2	Tyre size, front		mm	28x9-15
3.3	Tyre size, rear		mm	200/50-10
3.5	Wheels, number front/rear (x=drive wheels)			2X-2
3.6.1	Tread width, front	b_{10}	mm	1010
3.7.1	Tread width, rear	b_{11}	mm	955
4.0	Max lift height	H	mm	6000
4.1	Tilt of mast/fork carriage forward/backward		°	6/10
4.10	Height of wheel arms		mm	1110
4.12	Tow coupling height		mm	345
4.13	Loading height, unladen			0.28/0.36
4.15	Lowered height			1110
4.16	Length of loading surface			3688
4.17	Overhang			2180
4.19	Overall length		mm	3688
4.2	Retracted mast height	h_1	mm	2070
4.2.1	Overall height			4095
4.20	Length to face of forks	l ₂	mm	2618
4.21	Overall width	b_1/b_2	mm	1210
4.22	Fork dimensions	s/e/l	mm	50X122X1070
4.23	A,B Fork carriage class/type A, B			3A
4.24	Fork carriage width		mm	1100
4.3	Free lift		mm	135
4.31	Ground clearance, laden, below mast		mm	130
4.32	Ground clearance, centre of wheelbase		mm	185
4.34.1	Aisle width for pallets 1000×1200 crossways		Ast	4091
4.34.2	Aisle width for pallets 800×1200 lengthways		Ast	4291
4.35	Turning radius		Wa	2405
4.36	Internal turning radius			2405
4.4	Lift height	h_3	mm	3000

	SPECIFICATION	REF	UNIT	VALUE
4.5	Height, mast extended	h_4	mm	4095
4.7	Height of overhead guard (cabin)		mm	2180
4.8	Seat height/standing height		mm	1110
5.1	Travel speed, laden/unladen		km/h	16/17
5.10	Service brake			Hydraulic
5.11	Parking brake			Mechanical
5.2	Lifting speed, laden/unladen		m/s	0.4/0.5
5.3	Lowering speed, laden/unladen		m/s	0.43/0.44
5.8	Max. gradeability, laden/unladen		%	18/25
6.1	Drive motor rating S2 60 min		kW	17
6.2	Lift motor rating at S3 15%		kW	26
6.4	Battery nominal capacity		Ah	280
6.4	Battery voltage		V	80
6.4.1	Battery type			Li-Ion
6.6	Energy consumption according to DIN EN 16796		kWh/h	11.43
6.7	Turnover output according to VDI 2198			217
6.8	Turnover efficiency according to VDI 2198			22.01
8.1	Type of drive control			AC
10.5	Steering design			Hydraulic
10.7	Sound pressure level at the drivers ear		dB(A)	<74

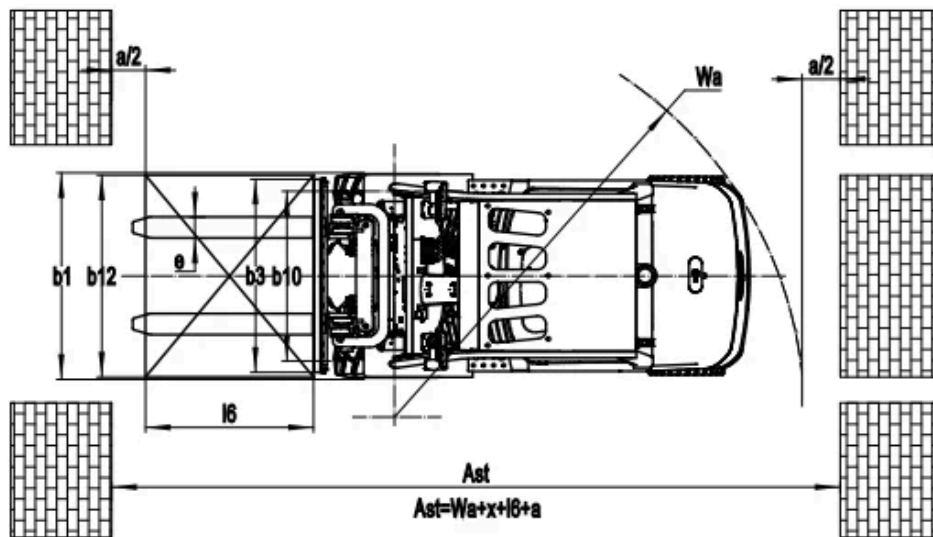
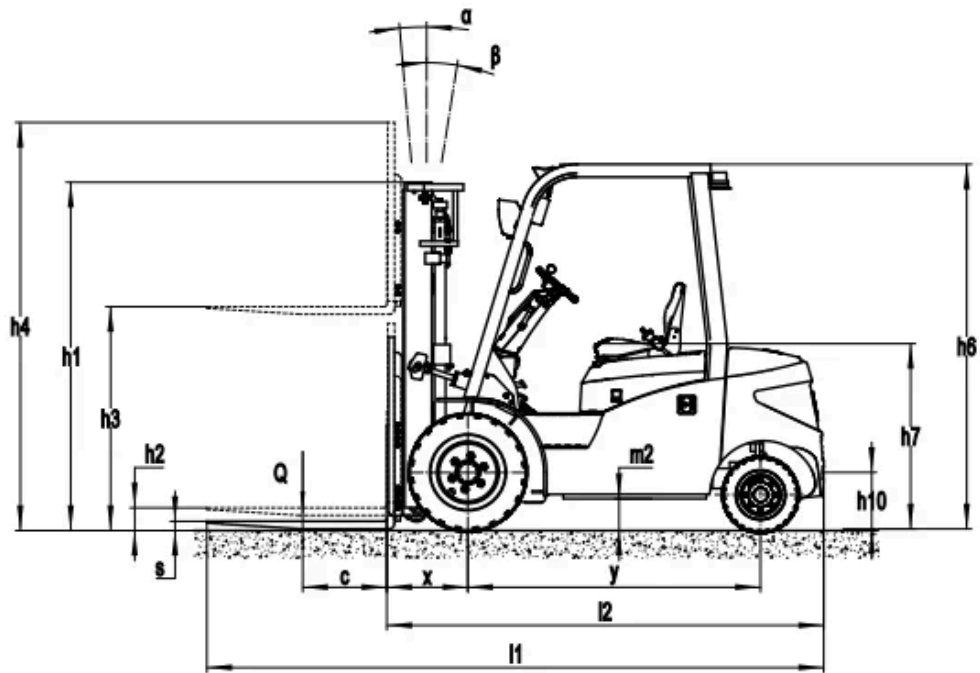

EFL353(S, P)

RATED CAPACITIES AND LOAD CENTERES GRAPH

SUBTRACT 100Kg WITH SIDE SHIFTER

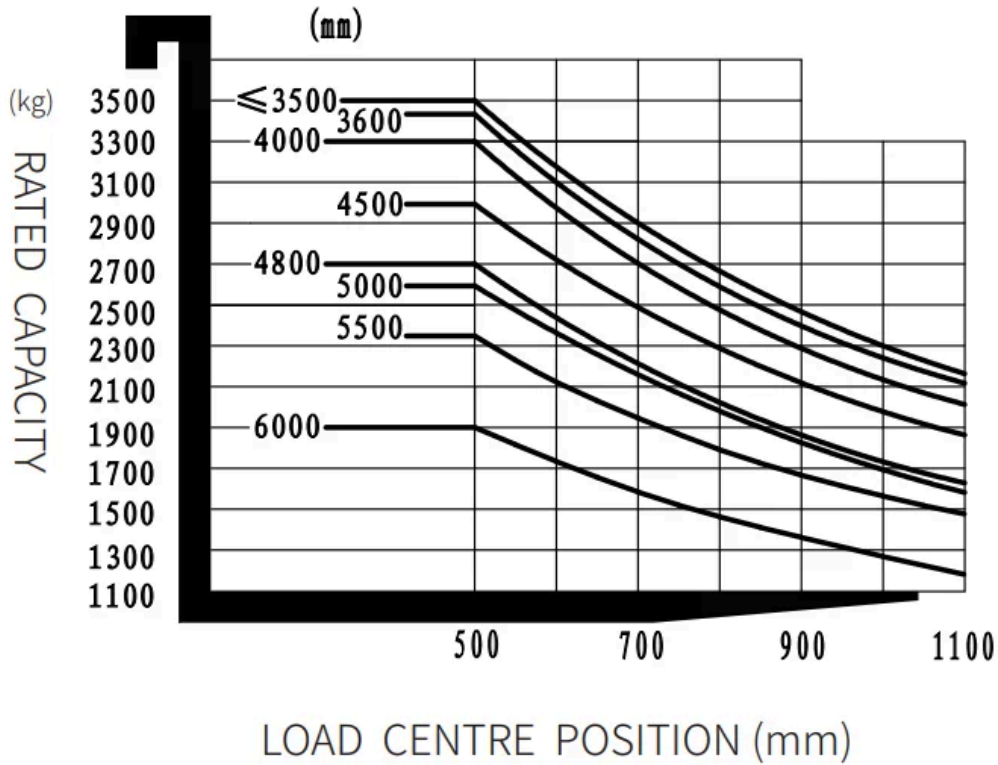

Mast Options

MAST TYPE	LIFT HEIGHT (H3, MM)	MAST LOWERED HEIGHT (H1, MM)	HEIGHT, MAST EXTENDED, NO SHELVIN G (H4, MM)	HEIGHT, MAST EXTENDED, WITH SHELVIN G (H4, MM)	HEIGHT, FREE LIFT, NO SHELVIN G (H2, MM)	HEIGHT, FREE LIFT, WITH SHELVIN G (H2, MM)	LOAD DISTANCE CENTRE OF DRIVE AXLE TO FORK (MM)	FORWARD TILT (A, DEG)	BACKWARD TILT (B, MM)	LOAD CAPACITY, SINGLE TYRE (KG)	LOAD CAPACITY, DOUBLE TYRE (KG)
2W270	2700	1920	3330	3795	135	135	486	6	10	3500	-
2W300	3000	2070	3630	4095	135	135	486	6	10	3500	-
2W330	3300	2220	3930	4395	135	135	486	6	10	3500	-
2W350	3500	2320	4130	4595	135	135	486	6	10	3500	-
2W360	3600	2370	4230	4695	135	135	486	6	10	3400	-
2W400	4000	2620	4630	5095	135	135	486	6	10	3300	-
2W450	4500	2870	5130	5595	135	135	486	6	6	3100	-

MAST TYPE	LIFT HEIGHT (H3, MM)	MAST LOWERED HEIGHT (H1, MM)	HEIGHT, MAST EXTENDED, NO SHELVING (H4, MM)	HEIGHT, MAST EXTENDED, WITH SHELVING (H4, MM)	HEIGHT, FREE LIFT, NO SHELVING (H2, MM)	HEIGHT, FREE LIFT, WITH SHELVING (H2, MM)	LOAD DISTANCE CENTRE OF DRIVE AXLE TO FORK (MM)	FORWARD TILT (A, DEG)	BACKWARD TILT (B, MM)	LOAD CAPACITY, SINGLE TYRE (KG)	LOAD CAPACITY, DOUBLE TYRE (KG)
2F300	3000	2040	3630	4095	1410	945	486	6	10	3500	-
2F330	3300	2190	3930	4395	1560	1095	486	6	10	3500	-
2F360	3600	2340	4230	4695	1710	1245	486	6	10	3500	-
3F430	4300	2040	4930	5395	1410	945	500	6	6	3300	-
3F450	4500	2120	5130	5595	1490	1025	500	6	6	3000	-
3F480	4800	2190	5430	5895	1560	1095	500	6	6	2700	-
3F500	5000	2310	5630	6095	1680	1215	500	6	6	2600	-
3F550	5500	2560	6130	6595	1930	1465	500	3	5	2350	-
3F600	6000	2810	6630	7095	2180	1715	500	3	5	1900	-

Options

ITEM	OPTIONS (optional items marked in yellow)
Fork dimension	122*50*1070 122*50*1150 122*50*1220 122*50*1370 122*50*1520 122*50*1600 122*50*1700 122*50*1820 122*50*2000 122*50*2420
Fork carriage width option	1100mm Yes and can be customized
Fork carriage height option	1095mm Yes and can be customized
Seat type	Regular Premium Suspension Suspension + seatbelt logic switch Suspension seat with armrest
Attachments	No Built-in sidsifter External shifter Fork positioner
Traction pin	Yes
Electrostatic chain	Yes
Battery and charger with heating function	No Yes and not customized
Front wheel type	Single Double
Front wheel material	Pneumatic Solid Non-marking
Battery capacity	80V460AH 80V230AH

ITEM	OPTIONS (optional items marked in yellow)
Charger	80V35A external 80V65A external 80V60A external 80V100A external 80V130A external 80V150A external 80V200A external
Battery display indicator (BDI)	With time
Area warning lamp	No Red, 1 left + 1 right
Rearview mirror	1 rearview mirror Add rearview mirror on both sides
Buzzer	Yes
OPS system	No Yes and not customized
USB interface	Yes
Telematics	Yes and not customized No
Front lamp	LED
Rear lamp	LED No
Warning lamp	Yes
Steering lamp	Yes
Blue lamp	No 2 front 1 rear 2 front+1 rear
Cabin	No Basic half cabin Upgrade half cabin Full cabin
Joystick	No Yes and not customized
Heater	No Yes and not customized