



# EFL302

## ELECTRIC COUNTERBALANCE FORKLIFT TRUCK 3.0T

3000 kg 6000 mm 80 V



Designed for both indoor warehouses and outdoor yards, the EFL 2 Series excels in logistics centers, production facilities, construction sites, and retail distribution. Its durable structure and powerful traction allow operation on uneven ground, while the compact turning radius and low overall length ensure high maneuverability in tight aisles. The integrated Li-ion battery enables opportunity charging at any time, providing flexible, continuous operation with no battery swaps or downtime.

SPECIFICATION	REF	UNIT	VALUE
Battery nominal capacity		Ah	205
Battery voltage		V	80
Load capacity	Q	kg	3000
Load centre distance	c	mm	500
Service weight		kg	4080
Retracted mast height	$h_1$	mm	2070
Lift height	$h_3$	mm	3000
Height, mast extended	$h_4$	mm	4110
Overall length		mm	3780
Overall width	$b_1/b_2$	mm	1230
Length to face of forks	l <sub>2</sub>	mm	2710
Fork dimensions	s/e/l	mm	45×122×1070
Turning radius		Wa	2500
Operator type			Seated
Load distance, centre of drive axle to fork		mm	481
Wheelbase		mm	1750

# Features

---

## Powerful and efficient Li-ion system

The EFL 2 Series features EP's 80V LFP Li-ion battery, providing safe, maintenance-free operation with long service life. Opportunity charging enables 24/7 uptime without battery replacement or water refilling.

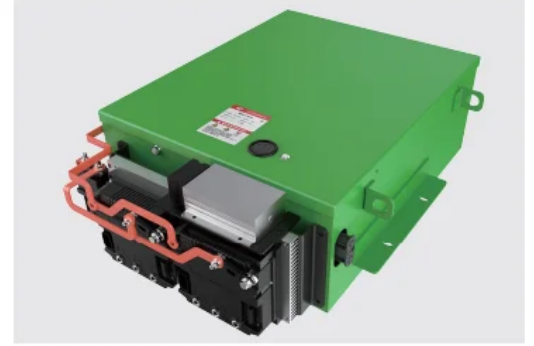

## IC-like performance, electric efficiency

Thanks to its strong drive motor and hydraulic system, the EFL 2 Series delivers power comparable to diesel forklifts, while reducing energy consumption and noise levels for more comfortable operation.

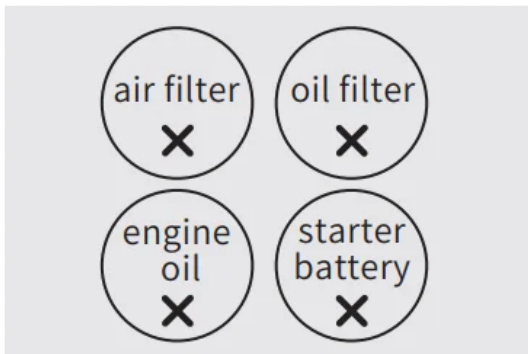

## Outdoor-ready and durable

Built with IPX4 water-resistant protection, large pneumatic tires, and a robust steel frame, the EFL 2 Series can operate reliably outdoors, on wet surfaces, and in light industrial yards.



## Smart management with telematics

Integrated telematics provide real-time fleet insights — including truck status, battery analytics, and usage reports — helping operators improve productivity and extend equipment lifespan.



# VDI Chart

	SPECIFICATION	REF	UNIT	VALUE
1.4	Operator type			Seated
1.5	Load capacity	Q	kg	3000
1.6	Load centre distance	c	mm	500
1.8	Load distance, centre of drive axle to fork		mm	481
1.9	Wheelbase		mm	1750
2.1	Service weight		kg	4080
2.2	Axle loading, laden front/rear		kg	6420/660
2.3	Axle loading, unladen front/rear		kg	1740/2340
3.1	Tyre type			Solidrubber
3.2	Tyre size, front		mm	28X9-15
3.3	Tyre size, rear		mm	6.50-10
3.5	Wheels, number front/rear (x=drive wheels)			2x/2
3.6.1	Tread width, front	$b_{10}$	mm	1010
3.7.1	Tread width, rear	$b_{11}$	mm	980
4.0	Max lift height	H	mm	6000
4.1	Tilt of mast/fork carriage forward/backward		°	6/10
4.12	Tow coupling height		mm	320
4.19	Overall length		mm	3780
4.2	Retracted mast height	$h_1$	mm	2070
4.2.1	Overall height			4110
4.20	Length to face of forks	l <sub>2</sub>	mm	2710
4.21	Overall width	$b_1/b_2$	mm	1230
4.22	Fork dimensions	s/e/l	mm	45×122×1070
4.23	A,B Fork carriage class/type A, B			3A
4.24	Fork carriage width		mm	1150
4.3	Free lift		mm	120
4.31	Ground clearance, laden, below mast		mm	120
4.32	Ground clearance, centre of wheelbase		mm	150
4.34.1	Aisle width for pallets 1000×1200 crossways		Ast	4181
4.34.2	Aisle width for pallets 800×1200 lengthways		Ast	4381
4.35	Turning radius		Wa	2500
4.4	Lift height	$h_3$	mm	3000

	SPECIFICATION	REF	UNIT	VALUE
4.5	Height, mast extended	$h_4$	mm	4110
4.6	Initial lift		mm	120
4.7	Height of overhead guard (cabin)		mm	2160
4.8	Seat height/standing height		mm	1130
5.1	Travel speed, laden/unladen		km/h	11/12
5.10	Service brake			Hydraulic
5.11	Parking brake			Mechanical
5.2	Lifting speed, laden/unladen		m/s	0.29/0.36
5.3	Lowering speed, laden/unladen		m/s	0.4/0.43
5.5	Drawbar pull, laden/unladen			6420/660
5.6	Max. drawbar pull, laden/unladen			6420/660
5.8	Max. gradeability, laden/unladen		%	15/15
6.1	Drive motor rating S2 60 min		kW	10
6.2	Lift motor rating at S3 15%		kW	16
6.4	Battery nominal capacity		Ah	205
6.4	Battery voltage		V	80
6.5	Battery weight		kg	4080
6.6	Energy consumption according to DIN EN 16796		kWh/h	0.29/0.36
6.7	Turnover output according to VDI 2198			Turnover output according to VDI 2198
6.8	Turnover efficiency according to VDI 2198			Turnover efficiency according to VDI 2198
8.1	Type of drive control			AC
10.5	Steering design			Hydraulic
10.7	Sound pressure level at the drivers ear		dB(A)	74
15.1	Charger output current		A	74

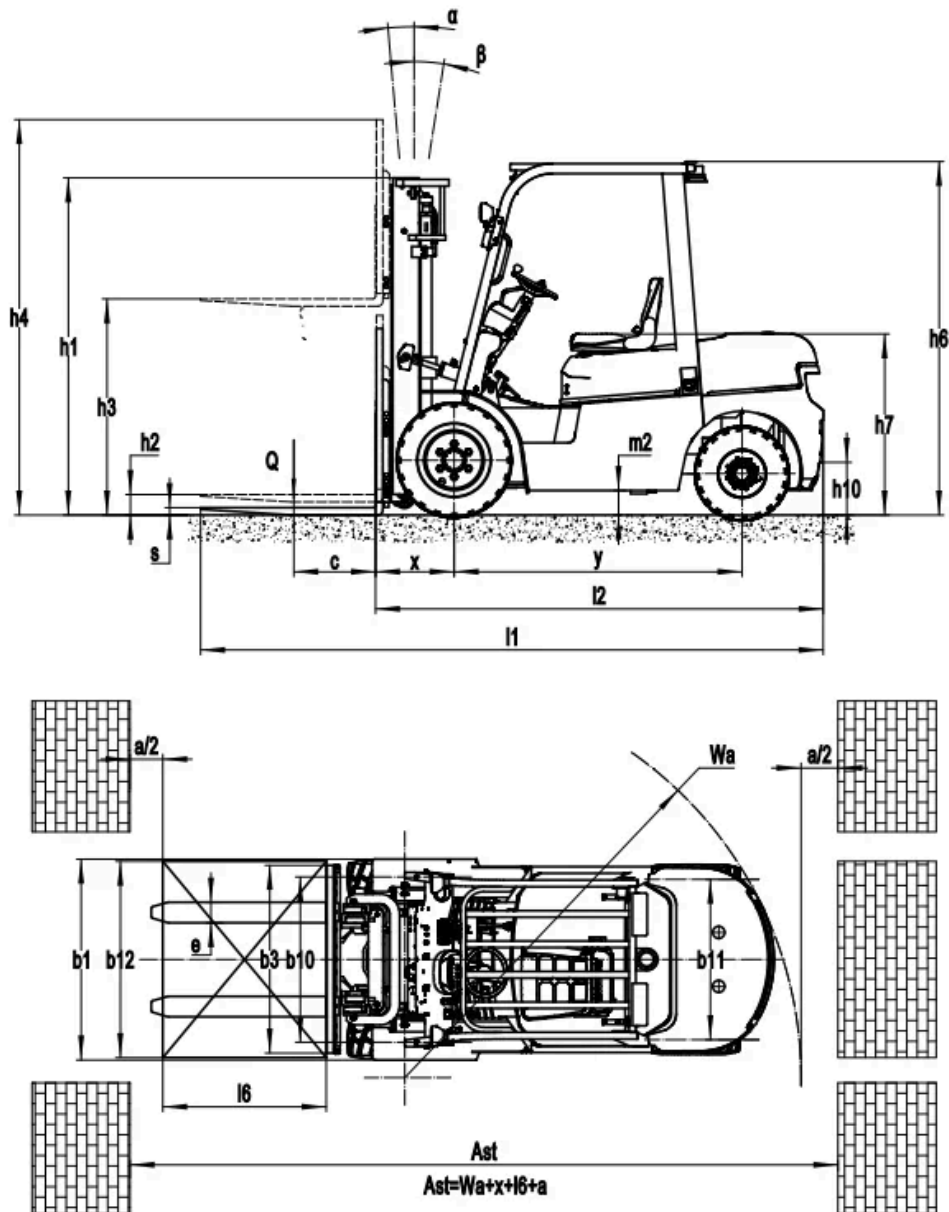

# EFL302

## RATED CAPACITIES AND LOAD CENTERES GRAPH

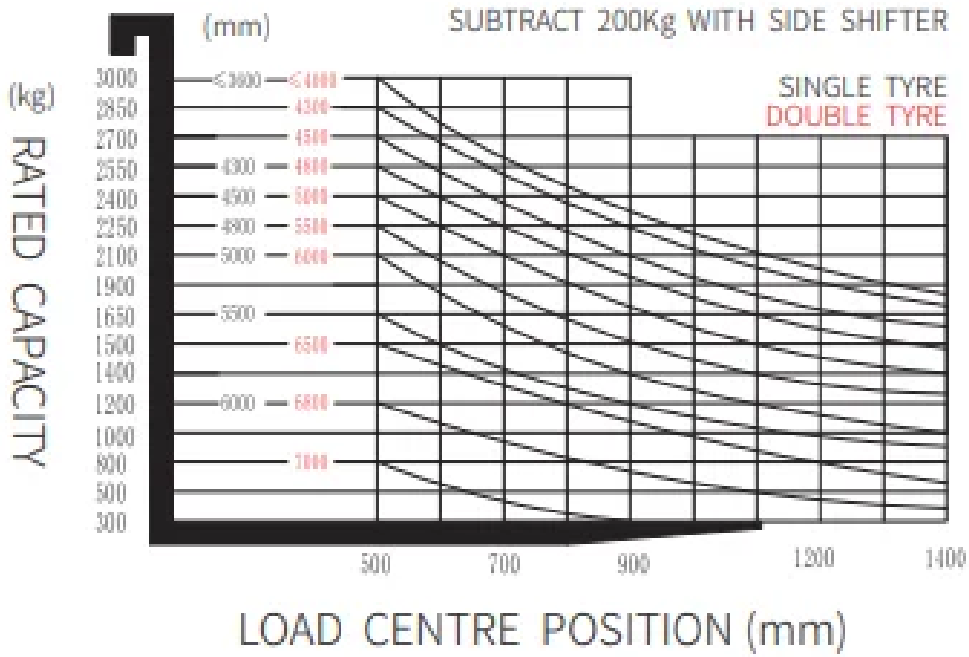

## Mast Options

MAST TYPE	LIFT HEIGHT (H3, MM)	MAST LOWERED HEIGHT (H1, MM)	HEIGHT, MAST EXTENDED, NO SHELVING (H4, MM)	HEIGHT, MAST EXTENDED, WITH SHELVING (H4, MM)	HEIGHT, FREE LIFT, NO SHELVING (H2, MM)	HEIGHT, FREE LIFT, WITH SHELVING (H2, MM)
2-Standard Mast	2700	1910	3330	3795	120	120
2-Standard Mast	3000	2060	3630	4095	120	120
2-Standard Mast	3300	2210	3930	4395	120	120
2-Standard Mast	3500	2310	4130	4595	120	120
2-Standard Mast	3600	2360	4230	4695	120	120
2-Standard Mast	4000	2610	4630	5095	120	120
2-Standard Mast	4300	2760	4930	5395	120	120
2-Standard Mast	4500	2860	5130	5595	120	120
2-Free Mast	3000	2040	3630	4095	1410	945
2-Free Mast	3300	2190	3930	4395	1560	1095
2-Free Mast	3600	2340	4230	4695	1710	1245

MAST TYPE	LIFT HEIGHT (H3, MM)	MAST LOWERED HEIGHT (H1, MM)	HEIGHT, MAST EXTENDED, NO SHELVING (H4, MM)	HEIGHT, MAST EXTENDED, WITH SHELVING (H4, MM)	HEIGHT, FREE LIFT, NO SHELVING (H2, MM)	HEIGHT, FREE LIFT, WITH SHELVING (H2, MM)
3-Free Mast	4300	2040	4930	5395	1410	945
3-Free Mast	4500	2120	5130	5595	1490	1025
3-Free Mast	4800	2225	5430	5895	1595	1130
3-Free Mast	5000	2310	5630	6095	1680	1215
3-Free Mast	5500	2560	6130	6595	1930	1465
3-Free Mast	6000	2810	6630	7095	2180	1715

## Options

ITEM	OPTIONS (optional items marked in yellow)
Fork dimension	122*45*1070   122*45*1150   122*45*1220   122*45*1370   122*45*1520   122*45*1600   122*45*1700   122*45*1820   122*45*2000   122*45*2200   122*45*2400
Fork carriage width option	1100mm   Yes and can be customized
Fork carriage height option	1095mm   Yes and can be customized
Seat type	Regular   Premium   Suspension   Suspension+seatbelt logic switch   Suspension seat with armrest(KL01)
Attachments	No   Built-in sidershifter   External shifter   Fork positioner
Traction pin	Yes
Front wheel material	Pneumatic   Solid   Non-marking
Battery capacity	80V205AH   80V280AH   80V410AH
Charger	80V35A   80V65A   80V130A   80V200A   80V35A integrated   80V60A integrated
Battery display indicator (BDI)	With time
Front lamp	LED
Rear lamp	No   LED
Warning lamp	YES