



CPD50L1

4-WHEEL LI-ION COUNTERBALANCE FORKLIFT 5.0 T

5000 kg 6000 mm 80 V Li-Ion



The CPD50L1 counterbalance forklift is suitable for heavy-duty, even the most demanding, applications thanks to the various lithium battery options and the improved travel speed. It delivers strong performance across industries such as beverage, timber, metal, construction and more. For container handling, the CPD50L1 with a dedicated mast can fully meet requirements due to its appropriate overhead guard height of 2250mm.

SPECIFICATION	REF	UNIT	VALUE
Battery type			Li-Ion
Battery nominal capacity		Ah	560
Battery voltage		V	80
Load capacity	Q	kg	5000
Load centre distance	c	mm	500
Service weight		kg	7000
Retracted mast height	h_1	mm	2230
Lift height	h_3	mm	3000
Height, mast extended	h_4	mm	4175
Overall length		mm	3970
Overall width	b_1/b_2	mm	1550
Length to face of forks	l2	mm	2900
Fork dimensions	s/e/l	mm	55X150X1070
Turning radius		Wa	2675
Operator type			Seated
Load distance, centre of drive axle to fork		mm	548

Features

New appearance combining practicality and aesthetic design

The new design of the CPD50L1 reflects both practicality and beauty. The internal layout has been optimised, resulting in a shorter l2 of 2900mm and a tighter turning radius of 2675mm. The compact size makes it easy to manoeuvre in confined spaces. The bolted overhead guard offers maximum flexibility for retrofit or replacement and the height of 2250mm combined with a triplex 4.5 metre lift allows for goods transportation in standard containers.



Different lithium battery capacity options to meet varying needs

The CPD50L1 offers two lithium battery options, 80V/560Ah and 80V/690Ah, to meet regular and intensive applications. It is designed around the advantages of lithium technology - opportunity charging, zero maintenance, zero carbon emissions and zero gas emissions during charging, which contributes to convenient and sustainable operation. The practical IP65 external plug provides charging convenience without the need to open the cover.



High travel speed for maximum efficiency

Compared to the classic CPD50F8, the travel speed of the CPD50L1 is improved to 16/18 km/h, speeding up warehouse turnover and increasing transport efficiency.





Joystick option for fatigue-free operation

The CPD50L1 can be fitted with hydraulic joystick controls instead of mechanical levers. Positioned at the end of the armrest, fingertip operation is possible, improving operator ergonomics with the following controls: all fork hydraulic control including the 4th way, driving direction (F-N-B), horn, emergency stop button.

Market-proven components and optimised layout

The CPD50L1 inherits mature components, such as the drive unit, motors, controllers and mast, ensuring great reliability. The box girder structure is more rigid, providing greater stability and the new hydraulic pump makes lifting operations more precise and quieter.



Ergonomic seat for a comfortable experience

The seat height (h7) is 1208mm from the ground, lower than others in its class. This makes it easy for the operator to get in and out.

VDI Chart

	SPECIFICATION	REF	UNIT	VALUE
1.4	Operator type			Seated
1.5	Load capacity	Q	kg	5000
1.6	Load centre distance	c	mm	500
1.8	Load distance, centre of drive axle to fork		mm	548
1.9	Wheelbase		mm	2000
2.1	Service weight		kg	7000
2.2	Axle loading, laden front/rear		kg	10840/1160
2.3	Axle loading, unladen front/rear		kg	3220/3780
3.1	Tyre type			Solidrubber
3.2	Tyre size, front		mm	28x12.5-15
3.3	Tyre size, rear		mm	23X10-12
3.5	Wheels, number front/rear (x=drive wheels)			2x/2

SPECIFICATION		REF	UNIT	VALUE
3.6.1	Tread width, front	b ₁₀	mm	1262
3.7.1	Tread width, rear	b ₁₁	mm	1085
4.0	Max lift height	H	mm	6000
4.1	Tilt of mast/fork carriage forward/backward		°	6/ 10
4.12	Tow coupling height		mm	555
4.19	Overall length		mm	3970
4.2	Retracted mast height	h ₁	mm	2230
4.20	Length to face of forks	l ₂	mm	2900
4.21	Overall width	b ₁ /b ₂	mm	1550
4.22	Fork dimensions	s/e/l	mm	55X150X1070
4.23	A,B Fork carriage class/type A, B			3A
4.24	Fork carriage width		mm	1250
4.3	Free lift		mm	150
4.31	Ground clearance, laden, below mast		mm	130
4.32	Ground clearance, centre of wheelbase		mm	150
4.34.1	Aisle width for pallets 1000×1200 crossways		Ast	4440
4.34.2	Aisle width for pallets 800×1200 lengthways		Ast	4640
4.35	Turning radius		Wa	2675
4.4	Lift height	h ₃	mm	3000
4.5	Height, mast extended	h ₄	mm	4175
4.7	Height of overhead guard (cabin)		mm	2250
4.8	Seat height/standing height		mm	1208
5.1	Travel speed, laden/unladen		km/h	16/18
5.10	Service brake			Hydraulic/Mechanical
5.11	Parking brake			Mechanical
5.2	Lifting speed, laden/unladen		m/s	0.3/0.46
5.3	Lowering speed, laden/unladen		m/s	0.45/ 0.51
5.8	Max. gradeability, laden/unladen		%	15/20
6.1	Drive motor rating S2 60 min		kW	18
6.2	Lift motor rating at S3 15%		kW	25.4
6.4	Battery nominal capacity		Ah	560
6.4	Battery voltage		V	80
6.4.1	Battery type			Li-Ion
6.5	Battery weight		kg	396

	SPECIFICATION	REF	UNIT	VALUE
6.6	Energy consumption according to DIN EN 16796		kWh/h	14.38 ¹⁾
6.7	Turnover output according to VDI 2198			300
6.8	Turnover efficiency according to VDI 2198			23.77
8.1	Type of drive control			AC
10.7	Sound pressure level at the drivers ear		dB(A)	70

VDI Drawing

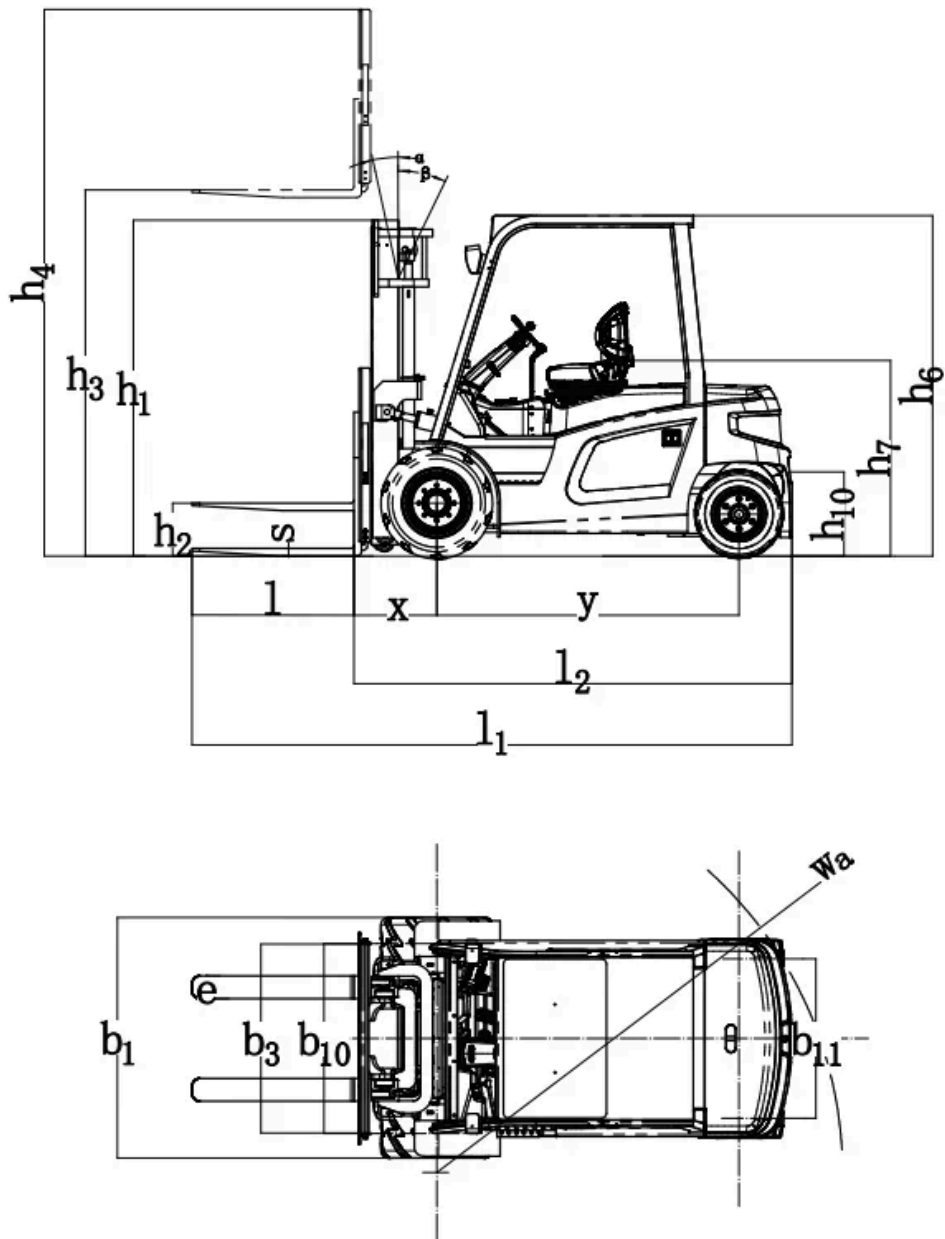

CAPACITY CHART

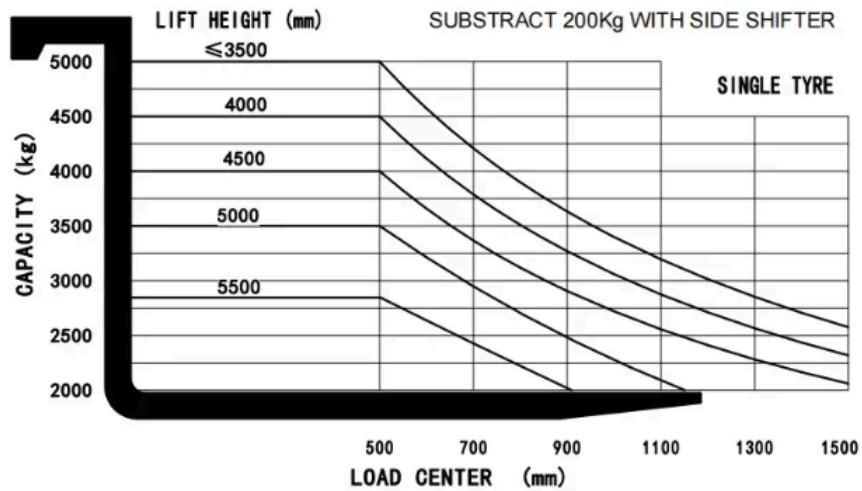

Options

ITEM	OPTIONS (optional items marked in yellow)
Fork dimension	150*55*1070 150*55*1220 150*55*1370 150*55*1520 150*55*1670 150*55*1820
Fork lowered height	1200 Yes and can be customized
Fork carriage width option	1250mm Yes and can be customized
Seat type	Premium Premium + seatbelt logic switch Suspension Suspension + seatbelt logic switch
Attachments	No Built-in sideshifter External shifter Fork positioner
Traction pin	Yes
Front wheel material	Solid Non-marking solid
Rear wheel material	Solid Non-marking solid
Battery capacity	80V560AH 80V690AH
Charger	80V200A 80V150A
Battery display indicator (BDI)	With time
Area warning lamp	No Red, 1 left + 1 right
Rearview mirror	1 rearview mirror Add 1 on both sides
Buzzer	Yes
OPS system	Yes
Telematics	No Yes and not customized

ITEM	OPTIONS (optional items marked in yellow)
Front lamp	LED
Rear lamp	No LED
Warning lamp	Yes
Blue lamp	No 2 front 1 rear 2 front + 1 rear
Cabin	No Basic semi-cabin Upgrade semi cabin Full cabin
Turn signal light	Yes