

CPD15TVL

3-WHEEL DUAL-DRIVE COUNTERBALANCE FORKLIFT 1.500 KG

📏 1500 kg 📏 5000 mm 🔋 80 V Li-Ion



Narrow Aisle: This counterbalance forklift can be used for a range of work applications including indoor warehousing and narrow aisle, with a turning radius starting from 1450mm for CPD15TVL to 1585mm for CPD20TVL.

Loading/Unloading: It offers great performance in loading and unloading tasks at docks or side bay lorries, supported by its powerful 80V battery. Ideal for the rental business due to its opportunity charging capability.

SPECIFICATION	REF	UNIT	VALUE
Battery type			Li-Ion
Battery nominal capacity		Ah	150
Battery voltage		V	80
Load capacity	Q	kg	1500
Load centre distance	c	mm	500
Service weight		kg	2950
Retracted mast height	h_1	mm	2075
Lift height	h_3	mm	3000
Height, mast extended	h_4	mm	4055
Overall length		mm	2733
Overall width	b_1/b_2	mm	1070
Length to face of forks	l2	mm	1813
Fork dimensions	s/e/l	mm	100X40X920
Turning radius		Wa	1450
Operator type			Seated
Load distance, centre of drive axle to fork		mm	420

Features

80 Volt System Offering Powerful Performance

The 80 voltage 2*5.0 kW dual drive motors offer higher power efficiency than regular 48 voltage, thus the TVL series has greatly enhanced its productivity of 6 working hours per charge.



Large Workspace

Due to the compact size of EP lithium battery and the ergonomic configuration of the control levers and the foot brake pedal, the small truck offers spacious legroom of 394mm and delivers the best in operation comfort.

Compact Truck Size

The TVL series features a small turning radius, 1450mm of CPD15TVL, 1550mm of CPD18TVL and 1585mm of CPD20TVL, which makes it a perfect workhorse for small warehouses with narrow aisles within 3.5 m.



Integrated Charger

The TVL series forklift comes with a EP Li-Ion battery and a 35A single phase integrated charger with 16 amp plug allowing the truck to be charged at any power outlets (except 10A and 13A civil plug in Switzerland and England).

Enhanced Mast with Optimal Visibility & Stability

The TVL series adopts the same high-strengthened mast of CPD20L2, offering the best all-around visibility and great stability with less wobbling even fully loaded.



VDI Chart

	SPECIFICATION	REF	UNIT	VALUE
1.4	Operator type			Seated
1.5	Load capacity	Q	kg	1500
1.6	Load centre distance	c	mm	500
1.8	Load distance, centre of drive axle to fork		mm	420
1.9	Wheelbase		mm	1230
2.1	Service weight		kg	2950
2.2	Axle loading, laden front/rear		kg	3928/522
2.3	Axle loading, unladen front/rear		kg	1305/1645
3.1	Tyre type			Solid
3.2	Tyre size, front		mm	18X7-8
3.3	Tyre size, rear		mm	15X4.5-8
3.5	Wheels, number front/rear (x=drive wheels)			2X/2
3.6.1	Tread width, front	b ₁₀	mm	943
3.7.1	Tread width, rear	b ₁₁	mm	175
4.0	Max lift height	H	mm	5000
4.1	Tilt of mast/fork carriage forward/backward		°	6/7
4.12	Tow coupling height		mm	600
4.19	Overall length		mm	2733
4.2	Retracted mast height	h ₁	mm	2075
4.20	Length to face of forks	l ₂	mm	1813
4.21	Overall width	b ₁ /b ₂	mm	1070
4.22	Fork dimensions	s/e/l	mm	100X40X920
4.23	A,B Fork carriage class/type A, B			2A
4.24	Fork carriage width		mm	1040
4.3	Free lift		mm	100
4.31	Ground clearance, laden, below mast		mm	89
4.32	Ground clearance, centre of wheelbase		mm	92

SPECIFICATION		REF	UNIT	VALUE
4.34.1	Aisle width for pallets 1000×1200 crossways		Ast	3175
4.34.2	Aisle width for pallets 800×1200 lengthways		Ast	3300
4.35	Turning radius		Wa	1450
4.4	Lift height	h ₃	mm	3000
4.5	Height, mast extended	h ₄	mm	4055
4.7	Height of overhead guard (cabin)		mm	2078
4.8	Seat height/standing height		mm	1050
5.1	Travel speed, laden/unladen		km/h	13/14
5.10	Service brake			Hydraulic
5.11	Parking brake			Mechanical
5.2	Lifting speed, laden/unladen		m/s	0.33/0.5
5.3	Lowering speed, laden/unladen		m/s	0.55/0.55
5.8	Max. gradeability, laden/unladen		%	10/15
6.1	Drive motor rating S2 60 min		kW	5.0X2
6.2	Lift motor rating at S3 15%		kW	11
6.4	Battery nominal capacity		Ah	150
6.4	Battery voltage		V	80
6.4.1	Battery type			Li-Ion
6.5	Battery weight		kg	165
8.1	Type of drive control			AC
10.5	Steering design			Hydraulic
10.7	Sound pressure level at the drivers ear		dB(A)	68

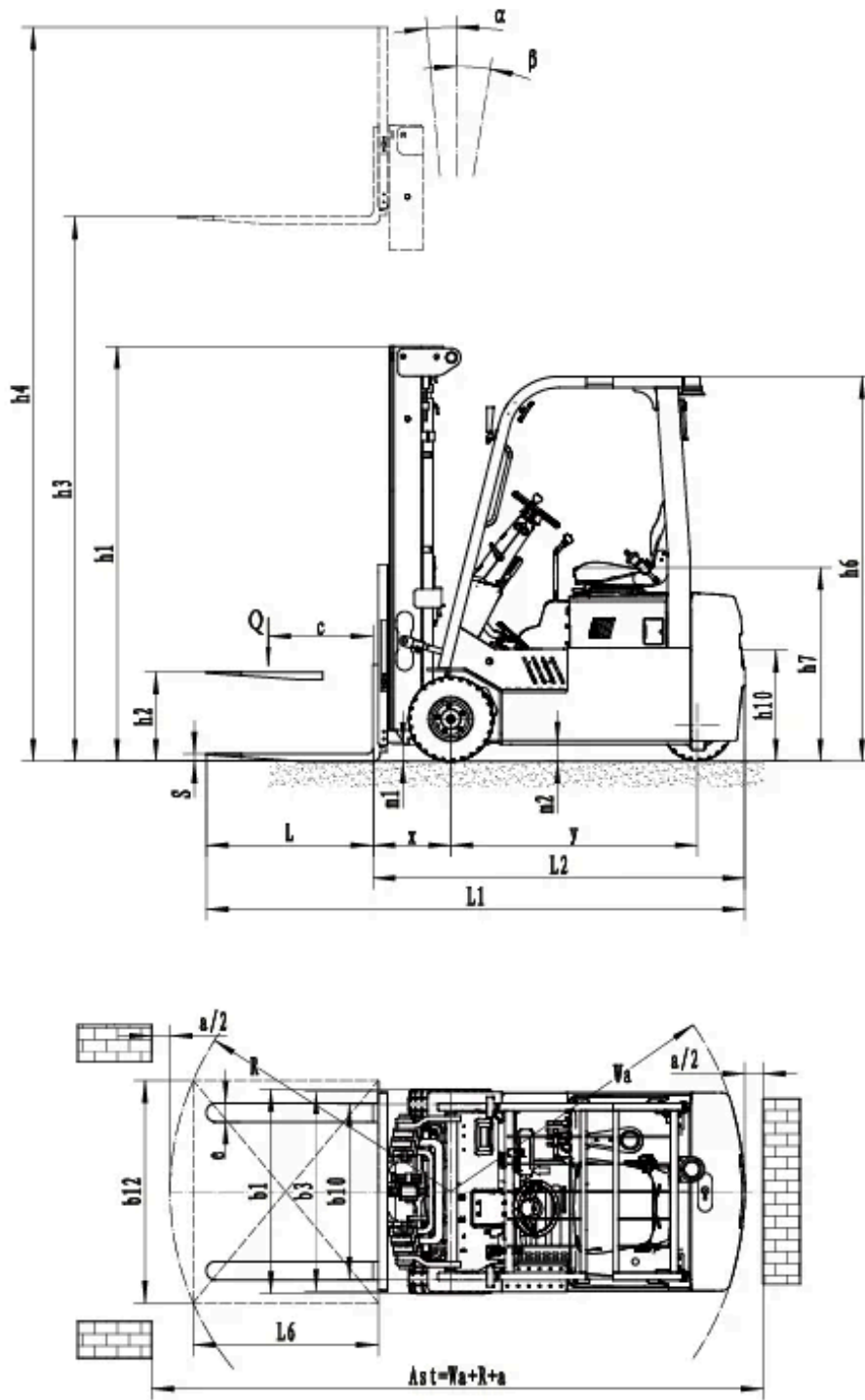

RATED CAPACITIES AND LOAD CENTERES GRAPH



Mast Options

MAST TYPE	LIFT HEIGHT (H3, MM)	MAST LOWERED HEIGHT (H1, MM)	MAST EXTENDED HEIGHT, NO BACKREST (H4, MM)	MAST EXTENDED HEIGHT, WITH BACKREST (H4, MM)	FREE LIFT HEIGHT, NO BACKREST (H2, MM)	FREE LIFT HEIGHT, WITH BACKREST (H2, MM)
2-Standard Mast	3000	2075	3740	4055	100	100
2-Standard Mast	3600	2375	4340	4655	100	100
2-Standard Mast	4000	2455	4740	5055	100	100
3-Free Mast	4500	2140	5240	5555	1430	1115
3-Free Mast	4800	2240	5540	5855	1530	1215
3-Free Mast	5000	2305	5740	6055	1595	1280

Options

ITEM	OPTIONS (optional items marked in yellow)
Fork dimension	s:100*40*920,o:100*40*1070,o:100*40*1100,o:100*40*1150,o:100*40*1220,o:100*40*1370,o:100*40*1520,o:100*40*1800

ITEM	OPTIONS (optional items marked in yellow)
Fork carriage width option	s:1040mm,o:Yes and can be customized
Seat type	s:Regular,o:Premium,o:Suspension,o:Suspension+seatbelt logic switch
Attachments	s:No,o:Built-in sideshifter,o:External shifter,o:Adjustable fork
Traction pin	s:Yes
Front wheel material	s:Solid,o: Non-marking solid
Battery capacity	s:150Ah,o:205Ah,o:280Ah
Charger	s:80V-35A single-phase integrated,o:80V-60A 3-phase integrated,o:80V-35A single-phase external,o:80V-65A 3-phase external
Battery display indicator (BDI)	s:With hourmeter
Area warning lamp	s:No,o:1 left + 1 right (Red)
Rearview mirror	s:1 in the middle,o:Add 1 rearview mirror on both sides
Buzzer	s:YES
OPS system	s:YES
Telematics	s:No,o:Yes and not customized
Front lamp	s:LED
Rear lamp	s:No,s:LED
Warning lamp	s:YES
Blue lamp	s:No,o:2 front,o:1 rear,o:2 front+ 1 rear
Cabin	s:No